



OPERATOR'S MANUAL

MODEL #BD100622
2 IN. (5 CM) SEMI-TRASH WATER PUMP



  **1-888-373-8272**
or visit black-diamond.com

SAVE THESE INSTRUCTIONS. This manual contains important safety precautions which should be read and understood before operating the product. Failure to do so could result in serious injury. This manual should remain with the product.
Specifications, descriptions and illustrations in this manual are as accurate as known at the time of publication, but are subject to change without notice.

TABLE OF CONTENTS

Table of Contents	2	Storage	27
Introduction	3	Water Pump Storage	27
Safety Definitions	3	Short Term Engine Storage (Up to 30 Days)	27
Important safety instructions	4	Mid Term Engine Storage (30 Days – 1 year)	27
Fuel Safety	6	Long Term Storage	27
Safety and Dataplate Labels	7	Specifications	29
Safety Symbols	8	Water Pump Specifications	29
Operation Symbols	10	Engine Specifications	29
Quick Start Label Symbols	10	Spark Plug Specifications	29
Controls and Features	11	Valve Specifications	29
Parts Included	12	Engine Oil Specifications	29
Assembly	13	Fuel Specifications	29
Remove the Water Pump from the Shipping Carton	13	Temperature Specifications	29
Install Wheels and Support Legs	13	Troubleshooting	30
Add Engine Oil	13	Warranty	32
Add Fuel	14	Warranty Qualifications	32
Operation	16	Repair/Replacement Warranty	32
Water Pump Location	16	Do Not Return The Unit To The Place Of Purchase	32
Connecting a Hose Kit	16	Warranty Exclusions	32
Priming the Pump	20	Other Exclusions	32
Before Starting the Engine	21	Limits of Implied Warranty and Consequential Damage	32
Starting the Engine	21	Contact Information	32
Stopping the Engine	22		
Operation at High Altitude	23		
Maintenance	24		
Cleaning the Water Pump	24		
Changing the Engine Oil	24		
Cleaning and Adjusting the Spark Plug(s)	24		
Cleaning the Air Filter	25		
Cleaning the Spark Arrestor	25		
Adjusting the Governor	26		
Maintenance Schedule	26		

INTRODUCTION

Congratulations on your purchase of a Black Diamond product. Black Diamond designs, builds, and supports all of our products to strict specifications and guidelines. With proper product knowledge, safe use, and regular maintenance, this product should bring years of satisfying service.

Every effort has been made to ensure the accuracy and completeness of the information in this manual at the time of publication, and we reserve the right to change, alter and/or improve the product and this document at any time without prior notice.

Since Black Diamond highly values how our products are designed, manufactured, operated and are serviced, and also highly value your safety and the safety of others, we would like you to take the time to review this product manual and other product materials thoroughly and be fully aware and knowledgeable of the assembly, operation, dangers and maintenance of the product before use. Fully familiarize yourself, and make sure others who plan on operating the product fully familiarize themselves too, with the proper safety and operation procedures before each use. Please always exercise common sense and always err on the side of caution when operating the product to ensure no accident, property damage, or injury occurs. We want you to continue to use and be satisfied with your Black Diamond product for years to come.

When contacting Black Diamond about parts and/or service, you will need to supply the complete model and serial numbers of your product. Transcribe the information found on your product's nameplate label to the table below

BLACK DIAMOND TECHNICAL SUPPORT TEAM
1-888-373-8272
MODEL NUMBER
BD100622
SERIAL NUMBER
DATE OF PURCHASE
PURCHASE LOCATION

SAFETY DEFINITIONS

The purpose of safety symbols is to attract your attention to possible dangers. The safety symbols, and their explanations, deserve your careful attention and understanding. The safety warnings do not by themselves eliminate any danger. The instructions or warnings they give are not substitutes for proper accident prevention measures.

DANGER

DANGER indicates a hazardous situation which, if not avoided, will result in death or serious injury.

WARNING

WARNING indicates a hazardous situation which, if not avoided, could result in death or serious injury.

CAUTION

CAUTION indicates a hazardous situation which, if not avoided, could result in minor or moderate injury.

NOTICE

NOTICE indicates information considered important, but not hazard-related (e.g., messages relating to property damage).

IMPORTANT SAFETY INSTRUCTIONS

⚠ WARNING

Cancer and Reproductive Harm – www.P65Warnings.ca.gov

⚠ DANGER

Water pump engine exhaust contains carbon monoxide, a colorless, odorless, poison gas. Breathing carbon monoxide will cause nausea, dizziness, fainting or death. If you start to feel dizzy or weak, get to fresh air immediately.

OPERATE THE WATER PUMP OUTDOORS ONLY IN A WELL VENTILATED AREA AND POINT EXHAUST AWAY.

DO NOT operate the water pump inside any building, including garages, basements, crawlspaces and sheds, enclosure or compartment, including the storage compartment of a recreational vehicle.

DO NOT allow exhaust fumes to enter a confined area through windows, doors, vents or other openings.

⚠ DANGER

Using an engine indoors **CAN KILL YOU IN MINUTES**. Engine exhaust contains carbon monoxide. This is a poison you cannot see or smell.

NEVER use inside a home or garage, **EVEN IF** doors and windows are open.

ONLY use **OUTSIDE** and far away from windows, doors, and vents.



Install battery-operated carbon monoxide alarms or plug-in carbon monoxide alarms with battery back-up according to the manufacturer's instructions.

⚠ DANGER

Rotating parts can entangle hands, feet, hair, clothing and/or accessories. Traumatic amputation or severe laceration can result.

Keep hands and feet away from rotating parts.

Tie up long hair and remove jewelry.

Operate equipment with guards in place.

DO NOT wear loose-fitting clothing, dangling drawstrings or items that could become caught.

⚠ WARNING

Spark from removed spark plug wire can result in fire or electrical shock.

When servicing the water pump:

Disconnect the spark plug wire and place it where it cannot contact the plug or any other metal object.

DO NOT check for spark with the plug removed.

Use only approved spark plug testers.

⚠ WARNING

Contact with electrical power source can cause electric shock or burn.

NEVER spray in the direction of or near a power source/ electrical outlet.

⚠ WARNING

Running engines produce heat. Severe burns can occur on contact. Combustible material can catch fire on contact.

DO NOT touch hot surfaces.

Avoid contact with hot exhaust gases.

Allow equipment to cool before touching.

Maintain at least 3 ft. (91.4 cm) of clearance on all sides to ensure adequate cooling.

Maintain at least 5 ft. (1.5 m) of clearance from combustible materials.

⚠ DANGER

DO NOT pump gasoline, fuel, fuel-oil mixtures, detergents, acids, chemicals, beverages, pesticides, fertilizers or any other flammable liquid or corrosive.

⚠ WARNING

DO NOT immerse the water pump in water.

IMPORTANT SAFETY INSTRUCTIONS

⚠ DANGER

The water pump develops powerful force.

DO NOT move the water pump when it is in use.

DO NOT use hoses or connectors that are worn, damaged or frayed.

DO NOT allow children or unqualified persons to operate or service the water pump.

DO NOT open top plug or drain plug.

⚠ WARNING

Rapid retraction of the starter cord will pull hand and arm towards the engine faster than you can let go. Broken bones, fractures, bruises or sprains could result. Unintentional startup can result in entanglement, traumatic amputation or laceration.

When starting engine, pull the starter cord slowly until resistance is felt and then pull rapidly to avoid kickback.

⚠ WARNING

DO NOT pump salt, sludge, sewer, sea, or any other type of water containing solid material.

⚠ CAUTION

Exceeding the pump specification for total head can damage the pump and/or hose kits connected to it.

DO NOT modify the pump in any way. DO NOT attempt to exceed the rated flow. Attempting to increase the rated flow may damage the unit and/or shorten its life.

🗨 NOTICE

DO NOT run the pump dry.

Running the pump dry can destroy the pump seals and will void the warranty. If the pump was running while dry, stop the engine and allow it to cool thoroughly before filling the chamber with water.

⚠ CAUTION

Improper treatment or use of the water pump can damage it, shorten its life and void your warranty.

Use the water pump only for intended uses.

Operate only on level surfaces.

DO NOT expose water pump to excessive moisture, dust, or dirt.

DO NOT allow any material to block the cooling slots.

DO NOT use the engine if:

- Equipment sparks, smokes or emits flames
- Equipment vibrates excessively

⚠ WARNING

Use of this water pump can create wet, slippery walking surfaces.

- Use only on a level surface.
- Make sure there is proper drainage to dissipate water.

IMPORTANT SAFETY INSTRUCTIONS

Fuel Safety

⚠ DANGER

GASOLINE AND GASOLINE VAPORS ARE HIGHLY FLAMMABLE AND EXPLOSIVE.

Fire or explosion can cause severe burns or death.

Gasoline and gasoline vapors:

- Gasoline is highly flammable and explosive.
- Gasoline can cause a fire or explosion if ignited.
- Gasoline is a liquid fuel but its vapors can ignite.
- Gasoline is a skin irritant and needs to be cleaned up immediately if spilled on skin or clothes.
- Gasoline has a distinctive odor, this will help detect potential leaks quickly.
- In any petroleum gas fire, flames should not be extinguished unless by doing so the fuel supply valve can be turned OFF. This is because if a fire is extinguished and a supply of fuel is not turned OFF, then an explosion hazard could be created.
- Gasoline expands or contracts with ambient temperatures. Never fill the gasoline tank to full capacity, as gasoline needs room to expand if temperatures rise.

When adding or removing gasoline:

DO NOT light or smoke cigarettes.

Turn the engine off and let it cool for at least two minutes before removing the gasoline cap. Loosen the cap slowly to relieve pressure in the tank.

Only fill or drain gasoline outdoors in a well-ventilated area.

DO NOT pump gasoline directly into the engine at the gas station. Use an approved container to transfer the fuel to the engine.

DO NOT overfill the gasoline tank.

Always keep gasoline away from sparks, open flames, pilot lights, heat and other sources of ignition.

When starting the engine:

DO NOT attempt to start a damaged engine.

Make certain that the gasoline cap, air filter, spark plug, fuel lines and exhaust system are properly in place.

Allow spilled gasoline to evaporate fully before attempting to start the engine.

Make certain that the water pump is resting firmly on level ground.

When operating the water pump:

DO NOT move or tip the water pump during operation.

DO NOT tip the water pump or allow fuel or oil to spill.

When transporting or servicing the water pump:

Make certain that the fuel valve is in the OFF position, the gasoline tank is empty.

Disconnect the spark plug wire.

When storing the water pump:

Store away from sparks, open flames, pilot lights, heat and other sources of ignition.

Do not store water pump or gasoline near furnaces, water heaters, or any other appliances that produce heat or have automatic ignitions.

⚠ WARNING

NEVER use a gasoline container, gasoline tank, or any other fuel item that is broken, cut, torn or damaged.

IMPORTANT SAFETY INSTRUCTIONS

Safety and Dataplate Labels

These labels warn you of potential hazards that can cause serious injury. Read them carefully.

If a label comes off or becomes hard to read, contact Technical Support Team for possible replacement.

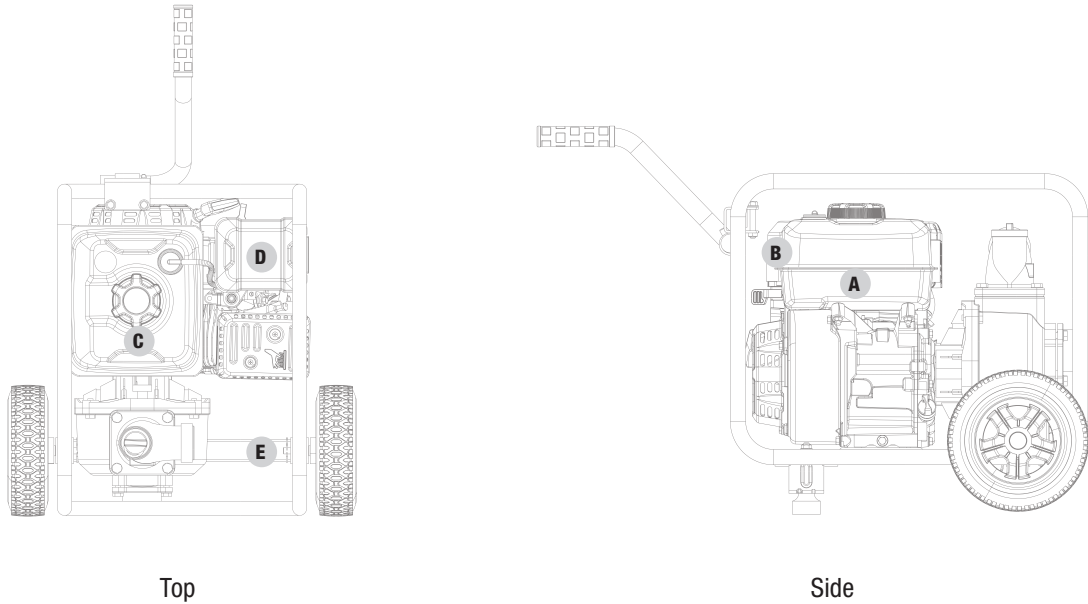

	LABEL	DESCRIPTION
A		Spark Arrestor Warning
B		Safety Symbols
C		Fuel
D		Hot Surface
E		Dataplate

IMPORTANT SAFETY INSTRUCTIONS

Safety Symbols

Some of the following symbols may be used on this product. Please study them and learn their meaning. Proper interpretation of these symbols will allow you to more safely operate the product.

SYMBOL	MEANING
	Read Operator's Manual. To reduce the risk of injury, user must read and understand operator's manual before using this product.
	Eye and Ear Protection. Always wear safety goggles or safety glasses with side shields, and as necessary a full face-shield as well as full ear protection when operating this product.
	Footwear. Always wear safety shoes or heavy boots when operating the machine.
	Gloves. Always wear nonslip, heavy-duty protective gloves when operating this product.
	Safety Alert. Precautions that involve your safety.
	Risk of Fire. Fuel and its vapors are extremely flammable and explosive. Fire can cause severe burns or death. Do not add fuel while the product is operating or still hot.
	Hot Surface. To reduce the risk of injury or damage, avoid contact with any hot surface
	Open Flame alert. Fuel and its vapors are extremely flammable and explosive. Keep fuel away from smoking, open flames, sparks, pilot lights, heat, and other ignition sources.



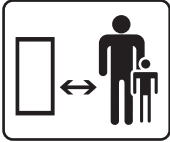

IMPORTANT SAFETY INSTRUCTIONS





SYMBOL	MEANING
	<p>Toxic Fumes. The engine exhaust from this product contains chemicals known to the state of California to cause cancer and birth defects and other reproductive harm.</p> <p>Risk of Asphyxiation. This engine emits carbon monoxide, an odorless, colorless poison gas. Breathing carbon monoxide can cause nausea, fainting or death. Use only in a well ventilated area.</p>
	<p>Clearance. Keep all objects including others at least 10 feet (3m) from this machine. Only one person should operate the water pump.</p>

IMPORTANT SAFETY INSTRUCTIONS

Operation Symbols

Some of the following symbols may be used on this product. Please study them and learn their meaning. Proper interpretation of these symbols will allow you to more safely operate the product.

SYMBOL	MEANING
	Choke. Pull choke knob to "CHOKE" position.
	Run. Push choke knob to "RUN" position.
	Fuel/Gasoline Valve On/Off
	Fuel Gauge: Full
	Fuel Gauge: Empty

SYMBOL	MEANING
	On
	Stop or Off
	Throttle Lever - Fast
	Throttle Lever - Slow

Quick Start Label Symbols

Some of the following symbols may be used on this product. Please study them and learn their meaning. Proper interpretation of these symbols will allow you to more safely operate the product.

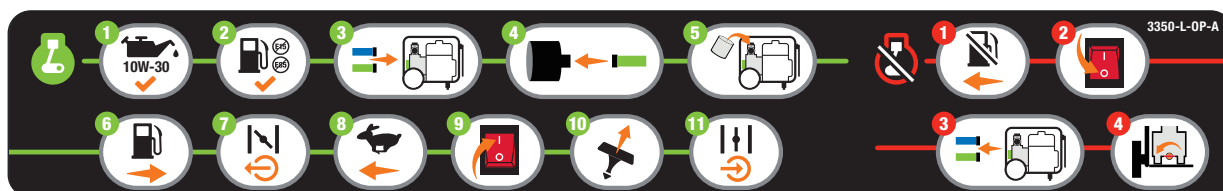

Starting the Engine

⚠ DANGER

Move water pump outside and far away from windows, doors and intake ventilation covers.

1. **Check oil level.** Recommended oil is 10W-30.
2. Check fuel level.
3. Connect inlet and outlet hoses
4. Connect inlet filter
5. Prime the water pump
6. Move the **fuel valve** to the "ON" position.
7. Move the **choke lever** to the "CHOKE" position by pulling out.
8. Move **throttle** to "FAST" position.
9. Press **engine switch** to "ON" position.

10. Pull the **starter cord** slowly until resistance is felt and then pull rapidly.

11. As engine warms up, move the **choke lever** to "RUN" by pushing in and adjust the throttle as needed

Stopping

1. Move the **fuel valve** to the "OFF" position.
2. Press the **engine switch** to the "OFF" position.
3. Disconnect inlet and outlet hoses for storage.
4. Remove drain plug (bottom) before storage.

CONTROLS AND FEATURES

Read this operator's manual before operating your water pump. Familiarize yourself with the location and function of the controls and features. Save this manual for future reference.

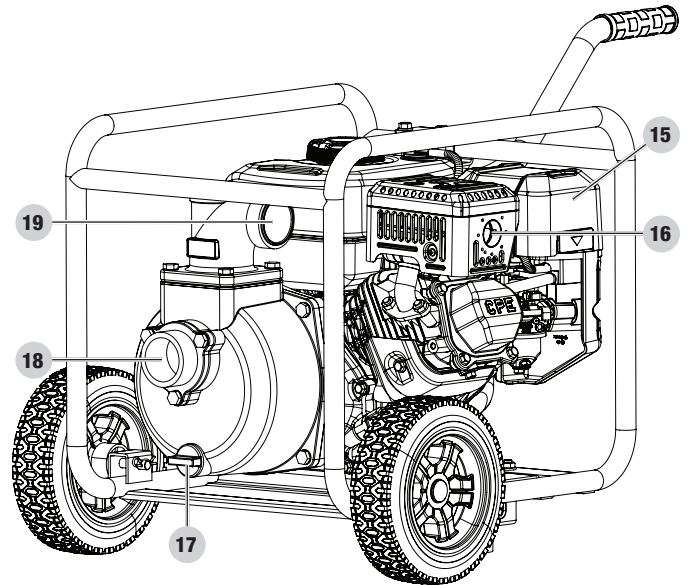
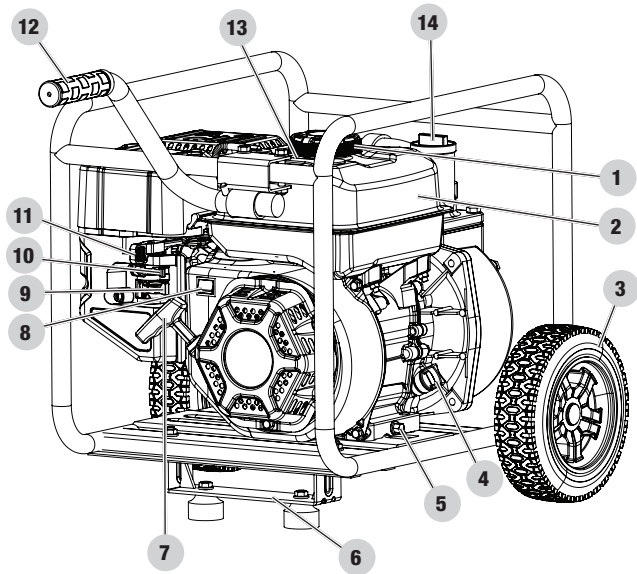

1. Fuel Tank Cap
2. Fuel Tank
3. Wheels
4. Engine Oil Fill Cap/Dipstick
5. Oil Drain Bolt
6. Support Leg
7. Recoil Handle
8. Engine Switch
9. Fuel Valve
10. Choke

11. Throttle
12. Transport Handle
13. Fuel Gauge
14. Priming Cap (top)
15. Air Filter
16. Muffler
17. Drain Plug (bottom)
18. Inlet
19. Outlet

Parts Included
Assembly Parts

Part	Part Qty.	Hardware Needed	Hardware Qty.	Tool Needed
Wheels	2	Pin Ø2 x 33, "R" Shape	2	N/A
		Roll Pin Ø16 x Ø10 x 97	2	
Support Leg w/Vibration Mounts	1	Flange Bolt M8x16	2	1× 12mm wrench or socket
		Nut M8	2	1× 12mm wrench or socket
Handle	1	Flange Bolt M8x45	2	1× 12mm wrench or socket
		Nut M8	2	1× 12mm wrench or socket
Discharge hose (blue)	1	Outlet hose adapter	1	N/A
		Outlet hose fitting	1	
		Gasket	1	
		Silver colored hose clamp 2 in. 52-55mm	1	1× 10mm wrench or socket
Green Suction hose (green)	1	Cam lock coupler (2 parts, coupler and fitting)	1	N/A
		Filter (2 parts)	1	
		Gold colored hose clamp 2 in. 54-57 mm	3	1× 10mm wrench or socket
Teflon Tape	1		N/A	
Spark Plug Socket	1		N/A	
Engine oil funnel	1		N/A	
Engine oil (10W-30, 0.6L)	1		N/A	

ASSEMBLY

Your water pump requires some assembly. This unit ships from the factory without oil. It must be properly serviced with fuel and oil before operation. For questions regarding the assembly of your water pump, call our help line at 1-888-373-8272. Please have your serial number and model number available.

Remove the Water Pump from the Shipping Carton

1. Set the shipping carton on a solid, flat surface.
2. Remove all contents from the carton except the water pump.
3. Carefully cut each corner of the box from top to bottom.

Install Wheels and Support Legs

Wheels

1. Slide the roll pin through the wheel from the outside.
2. Slide the roll pin through the mount point on the frame.
3. Secure with the R-clip.

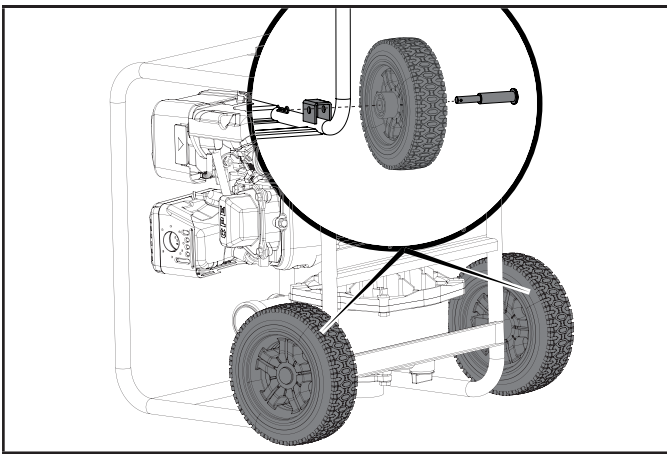

4. Repeat to attach the second wheel.
5. Add wheel caps to protect the roll pins.

Support Legs

1. Slowly tip the water pump backwards to rest on the frame on the pump end.
2. Align the mounting holes on the support leg with the mounting holes on the base plate of the water pump.
3. Insert an M8 x 16 flange bolt through the hole on the support leg and the hole on the base plate.
4. Thread an M8 nut onto each M8 x 16 flange bolt and tighten securely using a 12mm wrench or socket.

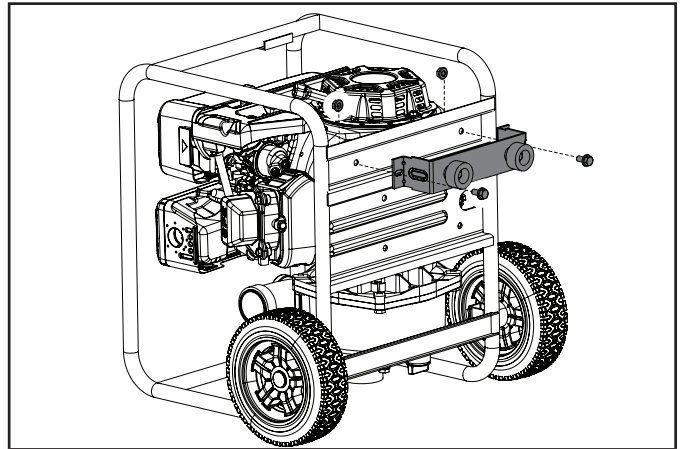

5. Slowly tip the water pump back down so that it rests on the support legs.

Install the Handle

1. Place the handle over the mounting channel on the frame.
2. Secure the handle to the frame using the two handle bolts (M8x45).
3. Place a lock nut (M8) on the end of each bolt and fasten securely. DO NOT over tighten the lock nuts.

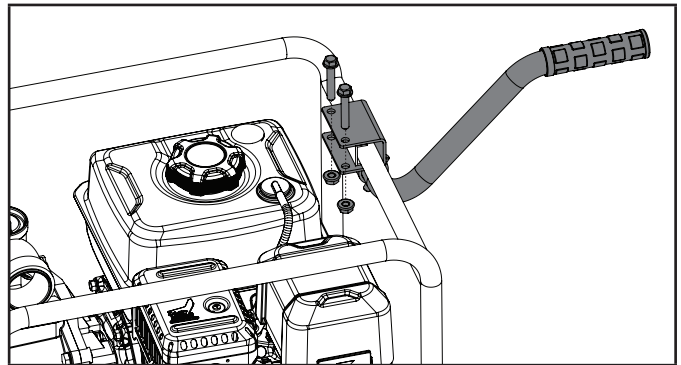

Add Engine Oil

⚠ WARNING

DO NOT attempt to crank or start the engine before it has been properly filled with the recommended type and amount of oil. Damage to the engine as a result of failure to follow these instructions will void your warranty.

🗨 NOTICE

The engine rotor has a sealed, pre-lubricated ball bearing that requires no additional lubrication for the life of the bearing.

NOTICE

The recommended oil type is **10W-30 automotive oil**.

If running engine in extreme temperatures, refer to the following chart for recommended oil type.

1. Place the water pump on a flat, level surface.
2. Remove oil fill cap/dipstick to add oil.
3. Using a funnel, add up to 20.3 fl. oz (600 ml) of oil (included) and replace oil fill cap/dipstick. **DO NOT OVERFILL.**

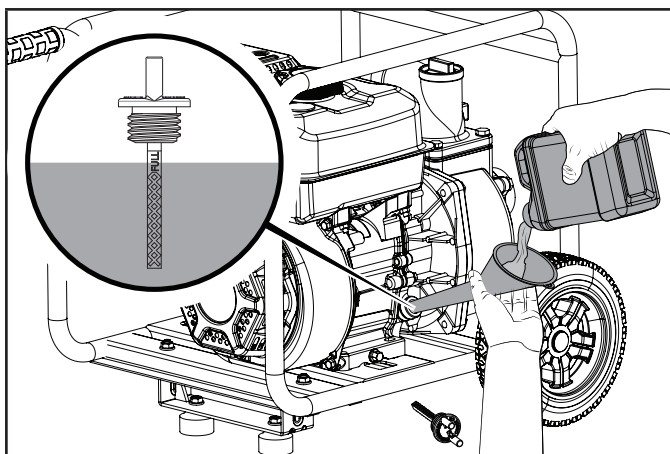

4. Check engine oil level before every use and add as needed.

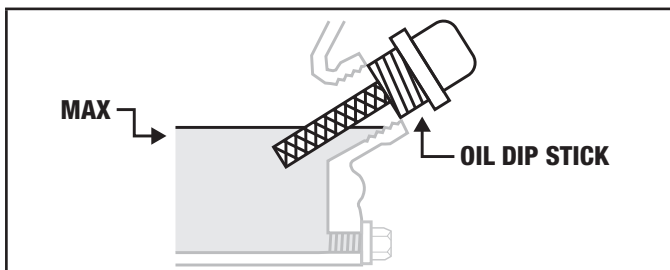

NOTICE

Once oil has been added, a visual check should show oil about 1-2 threads from running out of the fill hole.

If using the dipstick to check oil level, **DO NOT** screw in the dipstick while checking.

NOTICE

Check oil often during the break-in period. Refer to the Maintenance section for recommended service intervals.

CAUTION

The engine is equipped with a low oil shut-off and will stop when the oil level in the crankcase falls below the threshold level.

NOTICE

The first 5 hours of run time is the break-in period for the engine. During the break in period, it is recommended to use standard automotive, non-synthetic blended oils. After the break-in period, synthetic oil can be used but is not required.

Adjusting throttle setting will increase/decrease engine speed helping to seat piston rings. Avoid bogging or lugging the engine down and avoid prolonged running at constant RPM. After the 5-hour break-in period, change the oil.

NOTICE

Synthetic oil may be used after the 5 hour initial break-in period. Using synthetic oil does not decrease the recommended oil change interval. Full synthetic 5W-30 oil will aid in starting in cold ambient < 41° F (5° C).

Recommended Engine Oil Type	
10W-30	
5W-30	10W-40
5W-30 Full Synthetic	
°F	-20 0 20 40 60 80 100 120
°C	-28.9 -17.8 -6.7 4.4 15.6 26.7 37.8 48.9
Ambient temperature	

NOTICE

Weather will affect engine oil and engine performance. Change the type of engine oil used based on weather conditions to suit the engine needs.

Add Fuel

Use clean, fresh, regular unleaded gasoline with a minimum octane rating of 87 and an ethanol content of less than 10% by volume.

DO NOT mix oil with gasoline.

1. Place the water pump on a flat, level surface.
2. Remove the gasoline cap.
3. Slowly add gasoline to the tank. **DO NOT OVERFILL.** Gasoline can expand after filling. A minimum of ¼ in. (6.4 mm) of space left in the tank is required for gasoline expansion, although more than ¼ in. (6.4 mm) is recommended. Gasoline can be forced out of the tank as a result of expansion if overfilled, and can affect the stable running condition of the water pump. The approximate fuel level is shown on the fuel gauge on top of the fuel tank.

NOTICE

Our engines work well with 10% or less ethanol blended gasoline. When using ethanol-gasoline blends there are some issues worth noting:

- Ethanol-gasoline blends can absorb more water than gasoline alone.
- These blends can eventually separate, leaving water or a watery goo in the tank, fuel valve and carburetor.
- With gravity-fed supplies, the compromised gasoline can be drawn into the carburetor and cause damage to the engine and/or potential hazards.
- There are only a few suppliers of fuel stabilizer that are formulated to work with ethanol-gasoline blends.
- Any damages or hazards caused by using improper gasoline, improperly stored gasoline, and/or improperly formulated stabilizers, are not covered by manufacturer's warranty.

It is advisable to always shut off the gasoline supply, run the engine to starvation and drain the tank when the equipment is not in use for more than 30 days.

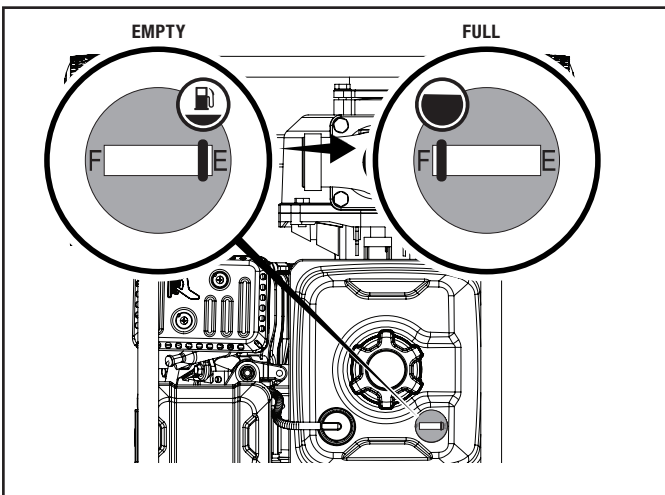
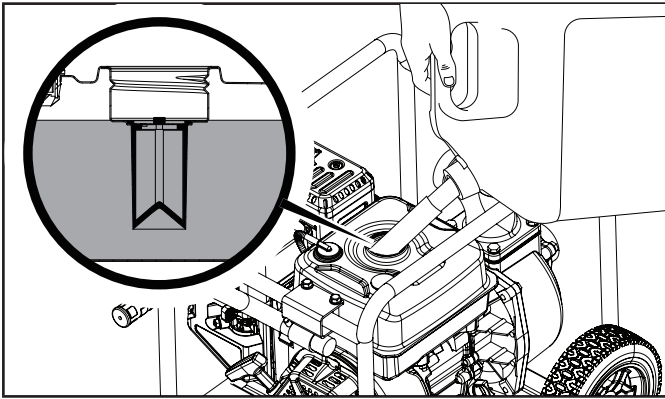

4. Screw on the gasoline cap and wipe away any spilled fuel.

CAUTION

Use regular unleaded gasoline with a minimum octane rating of 87 and an ethanol content of less than 10% by volume.

DO NOT light cigarettes or smoke when filling the tank.

DO NOT mix oil and gasoline.

Fill tank to approximately ¼ in. (6.4 mm) below the top of the tank to allow for gasoline expansion.

DO NOT pump gasoline directly into the water pump at the pump. Use an approved container to transfer the gasoline to the water pump.

DO NOT fill tank indoors.

DO NOT fill tank when the engine is running or hot.

DO NOT overfill the tank.

WARNING

Pouring gasoline too fast through the fuel screen may result in blow back of gasoline at the operator while filling.

OPERATION

Water Pump Location

⚠ DANGER

Water pump engine exhaust contains carbon monoxide, a colorless, odorless, poison gas. Breathing carbon monoxide will cause nausea, dizziness, fainting or death.

If you start to feel dizzy or weak, get to fresh air immediately.

OPERATE THE WATER PUMP OUTDOORS ONLY IN A WELL VENTILATED AREA AND POINT EXHAUST AWAY.

DO NOT operate the water pump inside any building, including garages, basements, crawlspaces and sheds, enclosure or compartment, including the storage compartment of a recreational vehicle.

DO NOT allow exhaust fumes to enter a confined area through windows, doors, vents or other openings.

⚠ DANGER

Using an engine indoors **CAN KILL YOU IN MINUTES**. Engine exhaust contains carbon monoxide. This is a poison you cannot see or smell.

NEVER use inside a home or garage, **EVEN IF** doors and windows are open.

ONLY use **OUTSIDE** and far away from windows, doors, and vents.

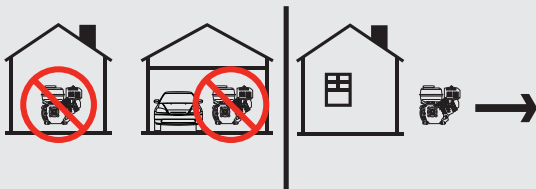

Install battery-operated carbon monoxide alarms or plug-in carbon monoxide alarms with battery back-up according to the manufacturer's instructions.

⚠ WARNING

Running engines produce heat. Severe burns can occur on contact. Combustible material can catch fire on contact.

DO NOT touch hot surfaces.

Avoid contact with hot exhaust gases.

Allow equipment to cool before touching.

Maintain at least 3 ft. (91.4 cm) of clearance on all sides to ensure adequate cooling.

Maintain at least 5 ft. (1.5 m) of clearance from combustible materials.

Place the water pump on a flat, level surface. The pump should be placed close to the water level to ensure maximum pump performance.

Pump output will be affected by the type, length, and size of the suction and discharge hoses. The pumping height, also known as the total head, is the distance from the water level to the point of discharge. As this distance increases, pump output decreases. The discharge capacity is greater than the suction capacity.

Therefore, it is important that the suction head is less than the discharge head. The time required to draw water from the source to the pump (self-priming time) can be decreased by minimizing the suction head.

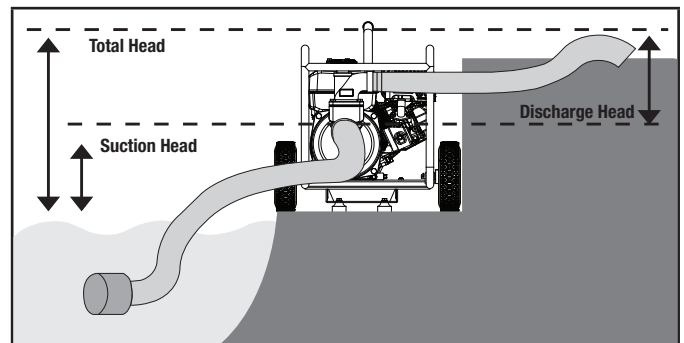

Connecting a Hose Kit

NOTICE

Both the inlet and outlet ports are 2 in. (5 cm) NPT. Please ensure the connectors to the suction and discharge hose are 2 in. (5 cm) NPT threaded.

Connect the Discharge Hose (Blue)

1. Locate (1) of the following: outlet hose adapter (C), gasket (A), and outlet hose fitting (B) and align for assembly.

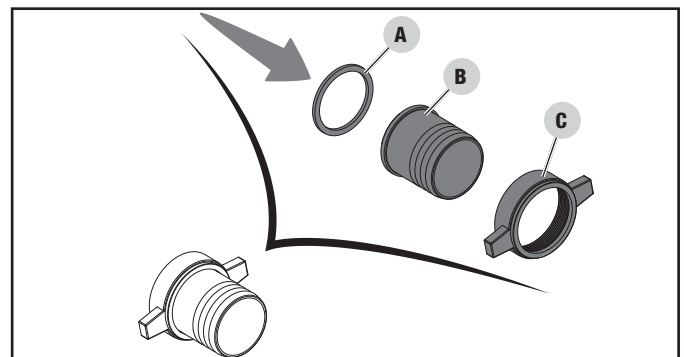

OPERATION

2. Thread the assembled connector to the outlet fitting (top of pump). Locate the blue “outlet” label on the pump.

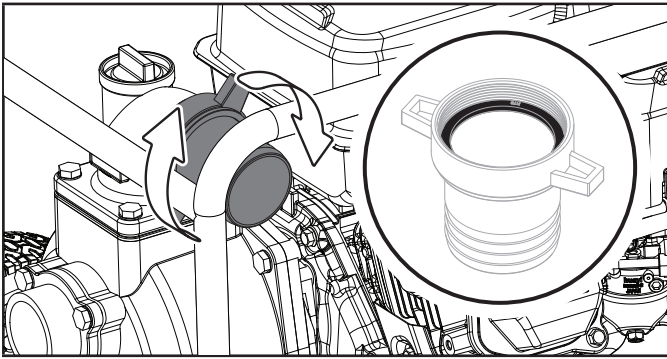

NOTICE

Make sure the gasket is seated inside before threading the adapter on.

3. Locate and slide the silver colored hose clamp (marked 52-55) over the blue outlet hose.

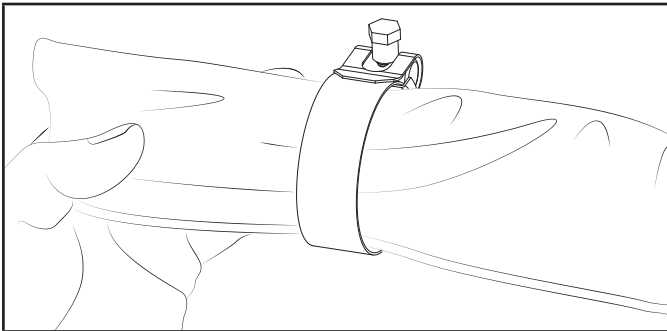

4. Slide the blue discharge hose over the outlet hose fitting.

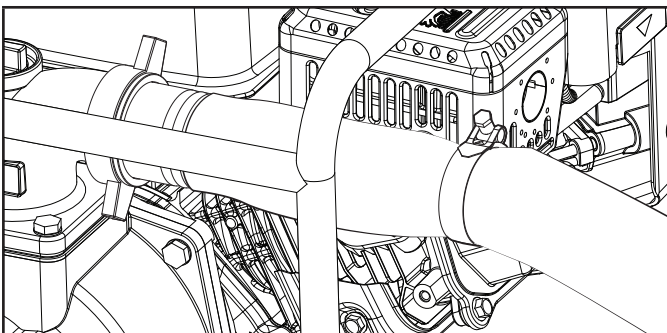

NOTICE

You may use a small amount of dish soap on the outlet hose fitting to help ease the outlet hose on the fitting. Work the soap around the fitting with your finger. Then work the blue hose on the outlet, by twisting and turning until it's fully seated.

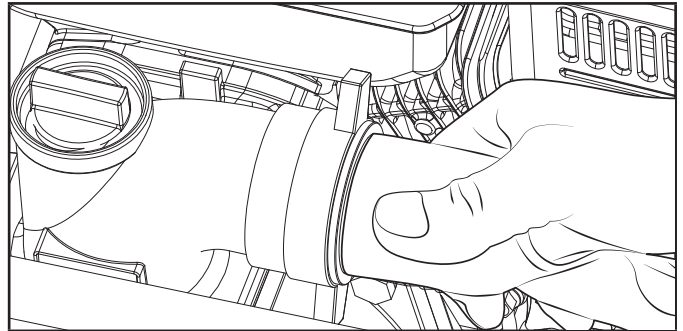

5. Slide the hose clamp in place about midway on the outlet hose adapter as shown. Tighten to 7.4 ± 1.5 lbf-ft (10 ± 2 Nm) with a 10mm wrench. The hose clamp should be placed behind the outlet adapter barbs on the smooth part of the adapter.

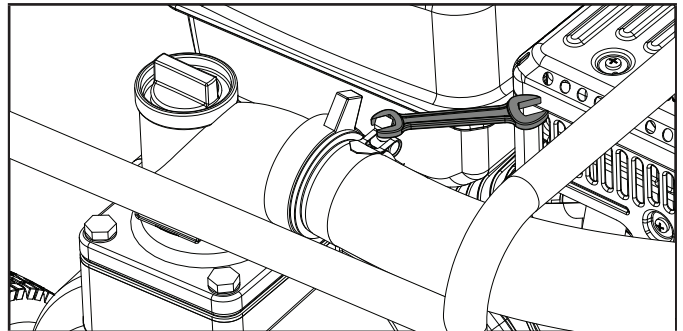

Connect the Suction Hose (Green) and Suction Filter

1. Locate the following: cam lock coupler (coupler and fitting together) (A), 54-57 marked hose clamps (B), Teflon® tape (C), green suction hose (D) and align for assembly.

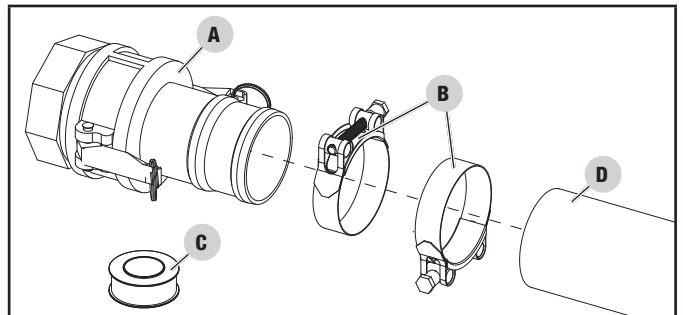

OPERATION

2. Cut ties and uncoil the green hose and use some weight to help straighten the hose out. Best to do this on a warmer day in the sun.

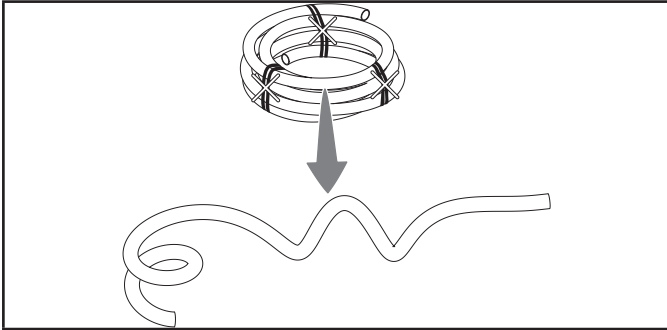

3. Separate the cam lock coupler and fitting. Align the green hose to the coupler and mark the locations of the ribs on the fitting.

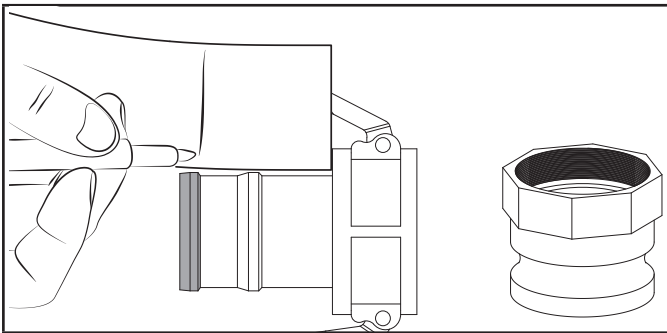

4. Mark the second rib on the coupler on the hose.

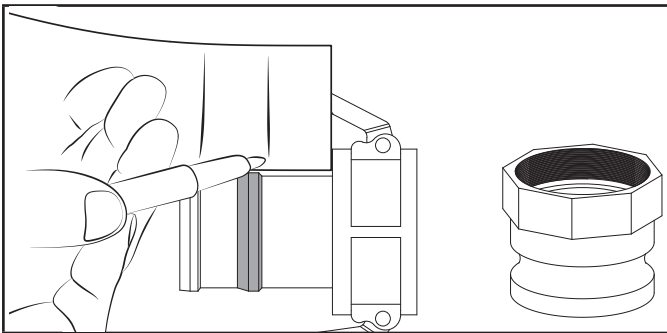

5. Lay the green hose side by side and place the clamp marked 54-57 in their approximate location.

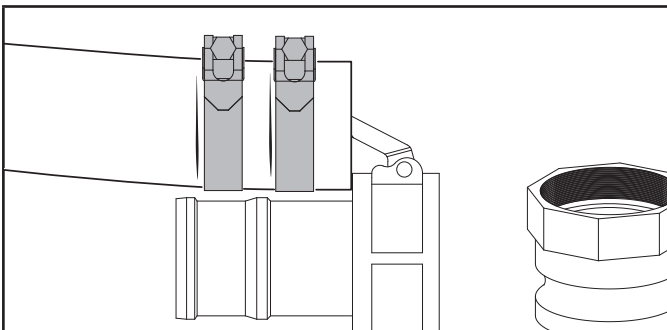

6. Slide the clamps back and start to assemble the green hose to cam lock coupler.

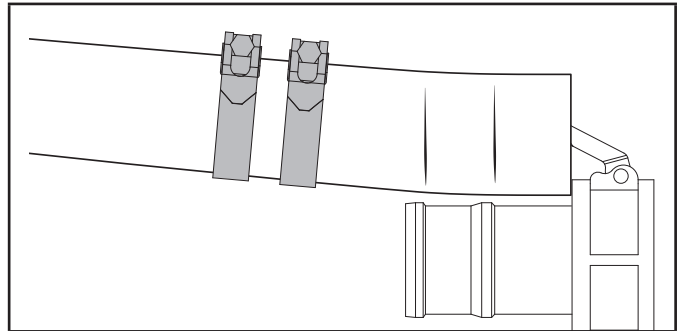

7. Insert the cam lock coupler in the green rigid suction hose until properly seated.

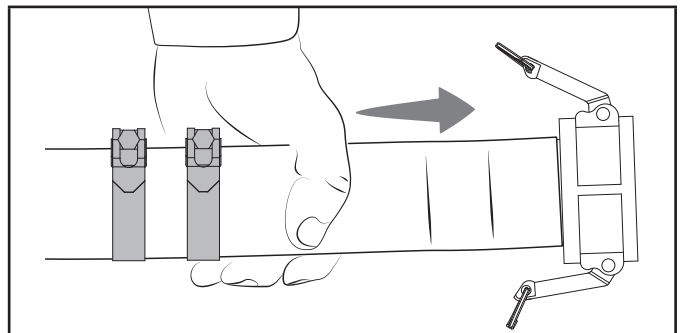

NOTICE

You may use a small amount of dish soap on the cam lock coupler to help ease the green hose on the fitting. Work the soap around the coupler with your finger. Then work the green hose on the fitting, by twisting and turning until it's fully seated.

You may need to dip the green suction hose into boiling water for 1 minute to install the hose as well. This will allow the material to stretch some while assembling the green hose to the cam lock coupler.

8. Slide the clamps marked 54-57 over cam lock coupler just past the marks you made on the hose earlier.

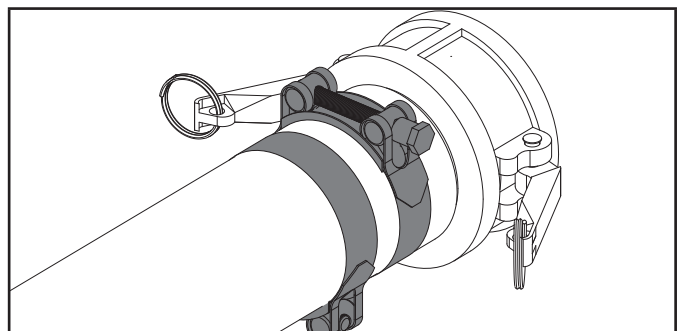

OPERATION

9. Rotate and align the clamp bolts so you have clearance for the cam levers to lock in place later.

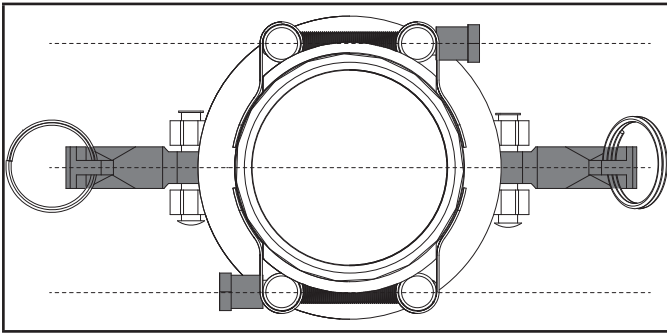

10. Tighten each clamp to 11.1 ± 1.5 lbf-ft (15 ± 2 Nm) with a 10mm socket and 3/8 in. drive ratchet until the clamp completely tightens. If you do not have a torque wrench, hand tight then 1/4 turn past full tight. This will need to be as tight as you can make them.

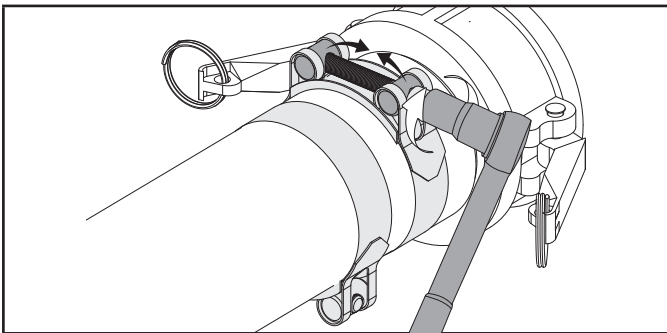

11. Once tightened, visually confirm the hose is raised on the ribs. This indicates you have it tight.

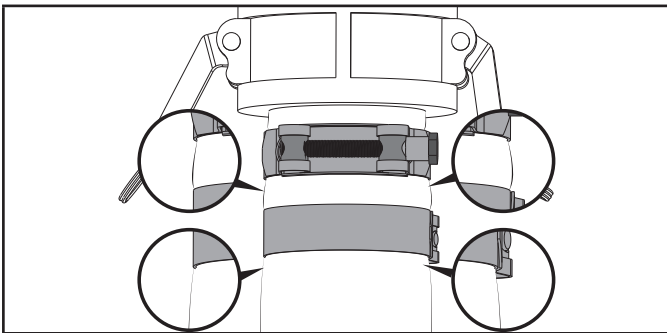

12. Test connection is tight by twisting coupler in the hose to make sure it doesn't turn. If coupling turns, then tighten clamps further until coupling won't turn.

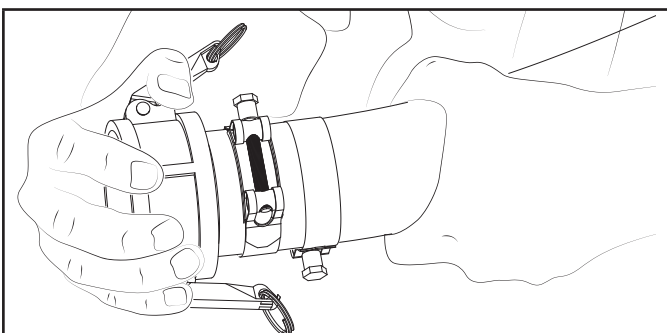

13. Wrap the green inlet clockwise with the Teflon® tape provided with 4 complete wraps.

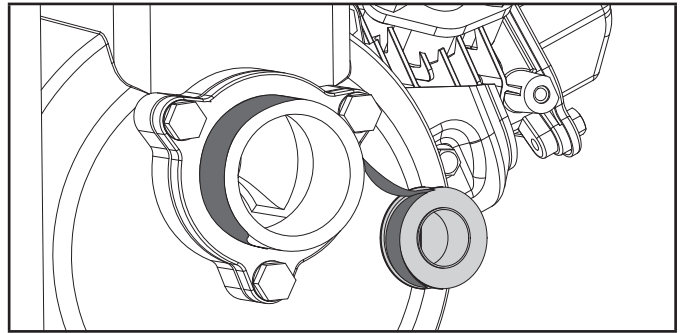

14. Thread the fitting over the tape and hand tighten. Use either 14 in. Channellock® or a pipe wrench with 2.5 in. (63.5mm) opening min, hand tight then 1 1/2 turn past full tight. This is critical to make sure the fitting is tight so you do not have air leaks.

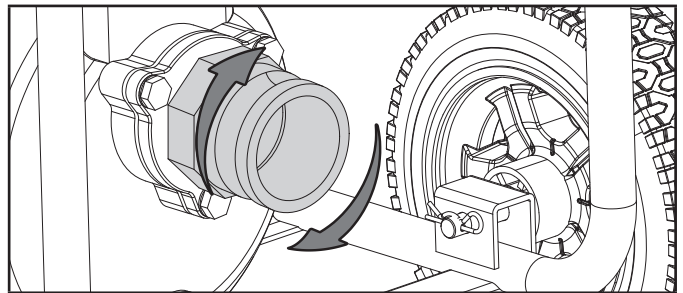

15. Attach the cam lock coupler to the fitting.

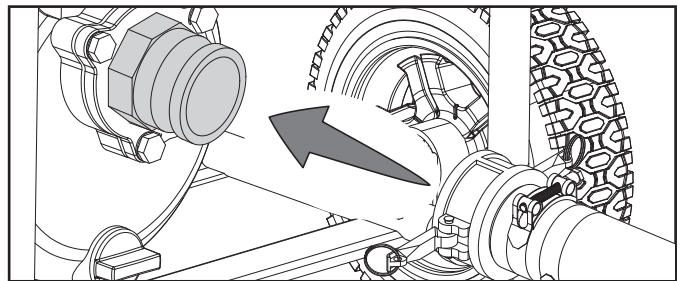

16. Lock in place with the cam levers.

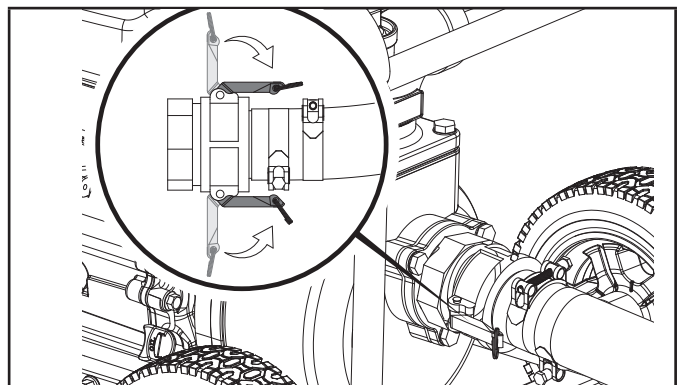

OPERATION

NOTICE

If the cam levers do not clamp down completely, rotate and align the clamp bolts so you have clearance for the cam levers to lock. See step 9 earlier.

17. Locate the following: filter (E) and 54-57 marked hose clamp (F).

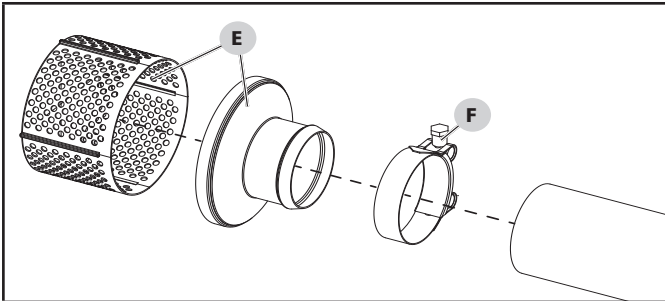

18. Snap the filter pieces together.

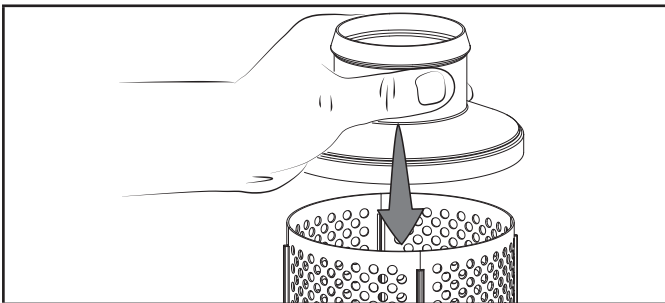

19. Place the clamp marked 54-57 on the other end of the green hose. Attach the strainer to the green suction hose.

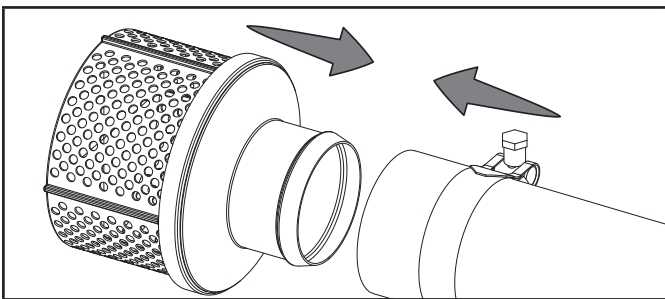

NOTICE

You may use a small amount of dish soap on the filter to help ease the green hose on the filter. Work the soap around the filter with your finger. Then work the green hose on the filter, by twisting and turning until it's fully seated.

20. Slide the clamp just before the end of the green hose.

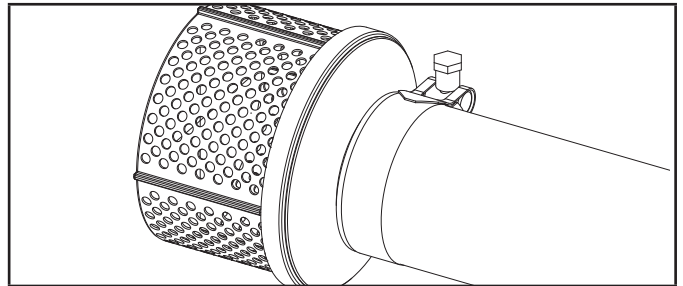

21. Tighten the clamp to 7.4 ± 1.5 lbf-ft (10 ± 2 Nm) with a 10mm wrench. If you do not have a torque wrench, hand tight then $\frac{1}{4}$ turn past full tight.

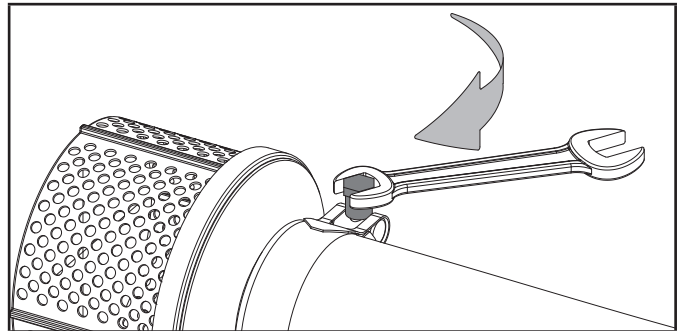

22. You should have everything connected.

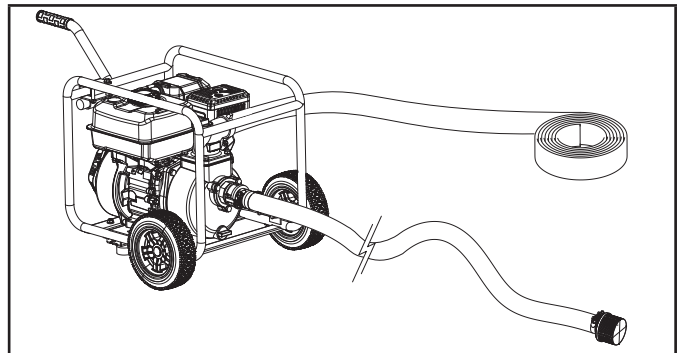

Priming the Pump

NOTICE

DO NOT run the pump dry.

Running the pump dry can destroy the pump seals and will void the warranty. If the pump was running while dry, stop the engine and allow it to cool thoroughly before filling the chamber with water.

NOTICE

Ensure the priming plug is secure before pump operation, if not secure the priming plug could be ejected and water or other liquids could be pumped through the top of the outlet flange.

OPERATION

1. Remove the priming cap (top) and fill pump body to the very top of outlet flange with water. Reinstall the priming plug. **DO NOT** over tighten.

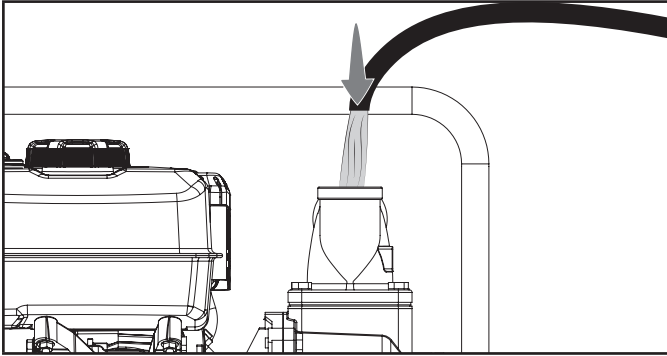

2. As the engine starts up, this will start the draw of liquid into the pump. Located within the pump assembly is the one-way valve. As you prime the pump housing this one-way flap valve shuts off the opening to the suction hose. The priming process is only required when the pump housing is not full of water.

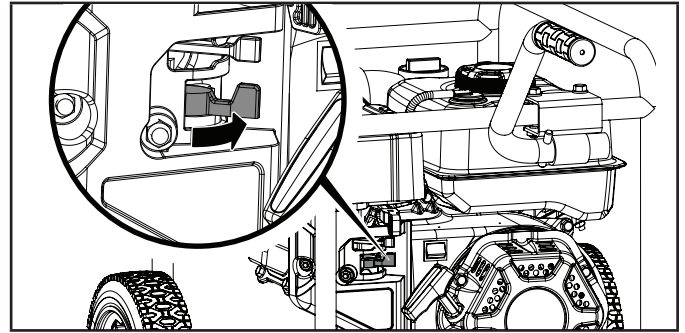

3. Move the choke lever to the “CHOKE” position.

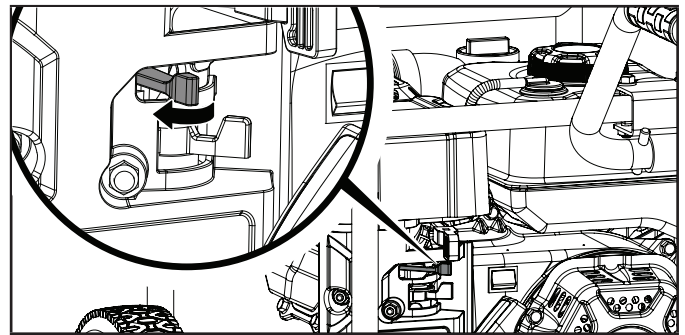

Before Starting the Engine

1. Route the suction hose so that the filter is immersed completely in the water supply source.
2. **DO NOT** operate pump without the filter fully immersed.
3. **DO NOT** operate the pump without the filter attached to the hose.
4. Secure the suction hose to keep it from moving once the water pump is started.
5. Route the discharge hose to the desired location. Secure the discharge hose to keep it from moving once the water pump is started.
6. Place the water pump on a flat, level surface.
7. Check that the oil is at the full mark on the dipstick, and that fuel has been added to the fuel tank.
8. Review the water pump assembly and ensure fittings are properly secured and make sure there are no kinks, cuts, or damage to hoses.

Starting the Engine

NOTICE

DO NOT run the pump without the unit primed and suction hose in the water. Damage to equipment resulting from failure to follow this instruction will void warranty.

1. Make certain the water pump is on a flat, level surface.
2. Move the fuel valve to the ON position

NOTICE

Keep choke lever in “CHOKE” position for 2 pulls of the recoil starter. After second pull, move choke lever to the “RUN” position for up to the next 3 pulls of the recoil starter. Too much choke leads to spark plug fouling/engine flooding due to the lack of incoming air. This will cause the engine not to start.

NOTICE

If the engine starts but does not run make certain that the unit is on a flat, level surface. The engine is equipped with a low oil sensor that will prevent the engine from running when the oil level falls below a critical threshold.

4. Move the throttle lever to the “FAST” position.

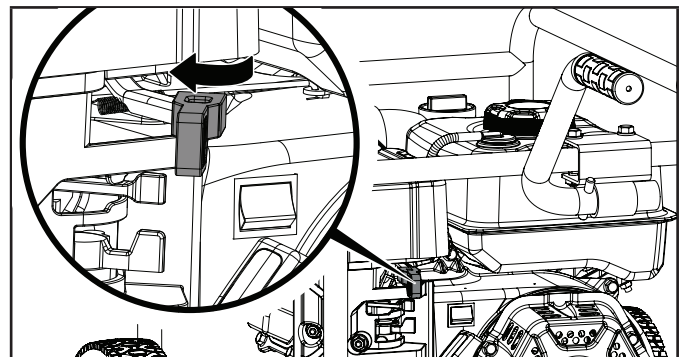

OPERATION

5. Press engine switch to "ON" position.

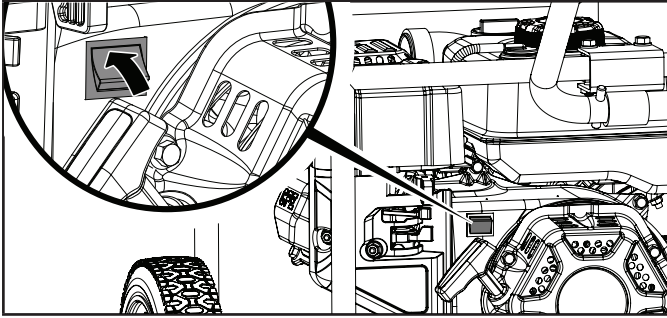

6. Pull the starter cord slowly until resistance is felt and then pull rapidly.

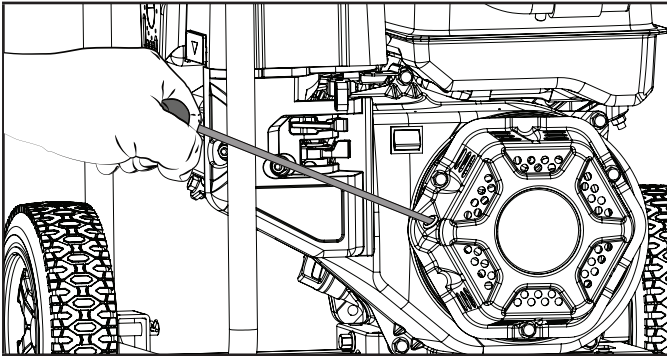

⚠ WARNING

Rapid retraction of the recoil cord will pull hand and arm towards the engine faster than you can let go. Unintentional startup can result in entanglement, traumatic amputation or laceration. Broken bones, fractures, bruises or sprains could result.

7. As engine warms up, move the choke to "RUN" by pushing in and adjust the throttle as needed

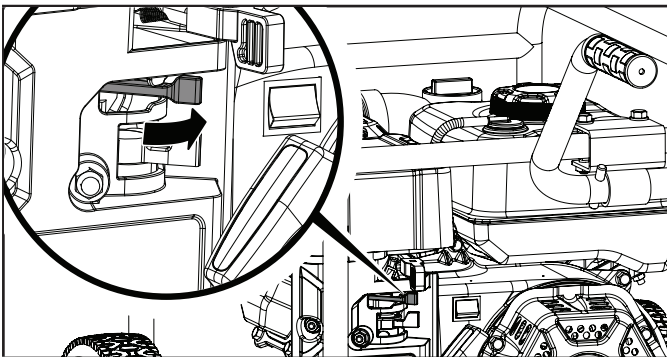

🗨 NOTICE

Water pump performance can be adjusted using the throttle. To decrease pump output, slide the throttle to the slow engine speed, towards "SLOW". To increase it, slide the throttle towards "FAST"

⚠ WARNING

DO NOT remove either top cap or bottom plug while the water pump is on and running. Loss of pressure and suction will occur. Injury may also occur.

Stopping the Engine

In an emergency, turn the engine switch to the "OFF".

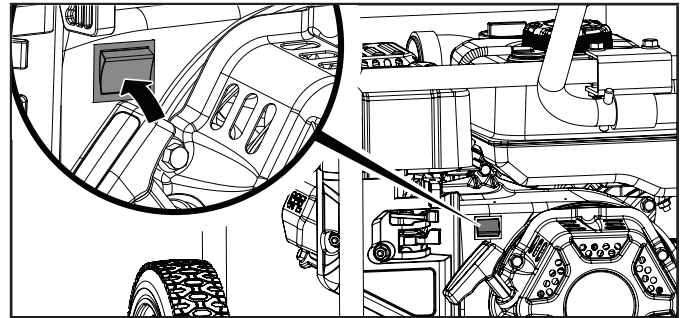

🗨 NOTICE

If the engine does not stop when the engine switch is moved to the "STOP" position, move the throttle to the slow speed position and slide the choke lever to the cold start (closed) position.

Under normal operation:

1. Move the fuel valve to the "OFF" position.

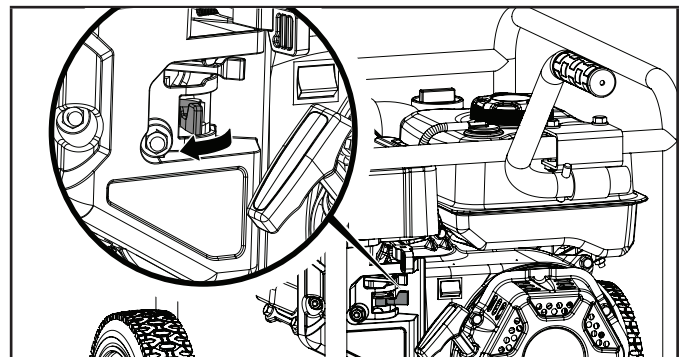

2. Let the engine run until fuel starvation has stopped the engine. This usually takes a few minutes.

Important: Always ensure that the fuel valve and the engine switch are in the "OFF" position when the engine is not in use.

Operation at High Altitude

The density of air at high altitude is lower than at sea level. Engine power is reduced as the air mass and air-fuel ratio decrease. Engine power and water pump output will be reduced approximately 3½% for every 1000 ft. of elevation above sea level. This is a natural trend and cannot be changed by adjusting the engine. At high altitudes increased exhaust emissions can also result due to the increased enrichment of the air fuel ratio. Other high altitude issues can include hard starting, increased fuel consumption and spark plug fouling.

To alleviate high altitude issues other than the natural power loss, Black Diamond can provide a high altitude carburetor main jet. The alternative main jet and installation instructions can be obtained by contacting our Technical Support Team.

The part number and recommended minimum altitude for the application of the high altitude carburetor main jet is listed in the table below.

In order to select the correct high altitude main jet it is necessary to identify the carburetor model. For this purpose, a code is stamped on the side of the carburetor. Select the correct high altitude jet part number corresponding to the carburetor code found on your particular carburetor.

⚠ WARNING

Operation using the alternative main jet at elevations lower than the recommended minimum altitude can damage the engine. For operation at lower elevations, the originally supplied standard main jet must be used. Operating the engine with the wrong engine configuration at a given altitude may increase its emissions and decrease fuel efficiency and performance.

MAINTENANCE

Make certain that the water pump is kept clean and stored properly. Only operate the unit on a flat, level surface in a clean, dry operating environment. DO NOT expose the unit to extreme conditions, excessive dust, dirt, moisture or corrosive vapors.

⚠ WARNING

Never operate a damaged or defective water pump.

⚠ WARNING

Improper maintenance will void your warranty.

🗨 NOTICE

For emission control devices and systems, read and understand your responsibilities for service as stated in the Emission Control Warranty Statement of this manual.

The owner/operator is responsible for all periodic maintenance.

Complete all scheduled maintenance in a timely manner.

Correct any issue before operating the water pump.

For service or parts assistance, contact our Technical Support Team at 1-888-373-8272.

Cleaning the Water Pump

⚠ CAUTION

DO NOT spray water pump with water.

Water can contaminate the fuel system and can enter the engine through the cooling slots and damage the engine.

1. Use a damp cloth to clean exterior surfaces of the water pump.
2. Use a soft bristle brush to remove dirt and oil.
3. Use an air compressor (25 PSI) to clear dirt and debris from the water pump.
4. Inspect all air vents and cooling slots to ensure that they are clean and unobstructed.

Changing the Engine Oil

Change oil when the engine is warm. Refer to the oil specification to select the proper grade for your operating environment.

1. Remove the oil drain bolt with a 12 mm socket (not included) and extension.

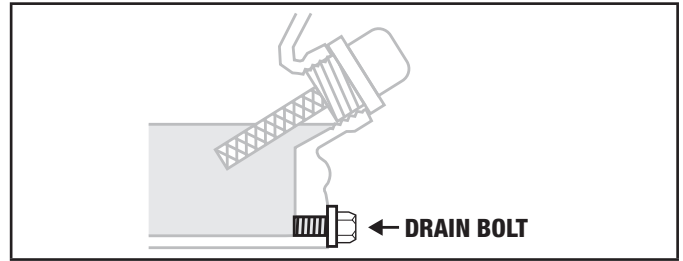

2. Allow the oil to drain completely into an appropriate container.

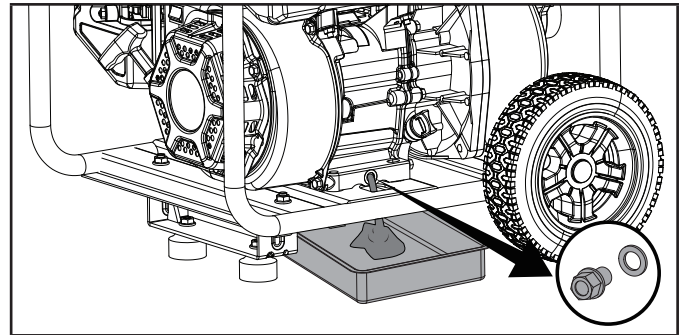

3. Replace the oil drain bolt. Tighten to 14.7 lbf-ft – 17.6 lbf-ft (20-24 Nm).
4. Add oil according to “Add Engine Oil” in Assembly section. DO NOT OVERFILL. Oil not included for routine maintenance.
5. Dispose of used oil at an approved waste management facility.

🗨 NOTICE

Once oil has been added, a visual check should show oil about 1-2 threads from running out of the fill hole. If using the dipstick to check oil level, DO NOT screw in the dipstick while checking.

Cleaning and Adjusting the Spark Plug(s)

1. Remove the spark plug cable from the spark plug.

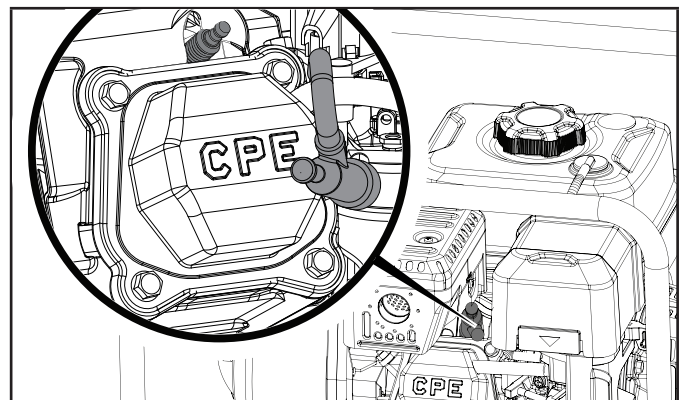

MAINTENANCE

2. Use a spark plug socket tool (included), or a 13/16 in. (21 mm) (not included) socket to remove the plug.
3. Inspect the electrode on the plug. It must be clean and not worn to produce the spark required for ignition.
4. Make certain the spark plug gap is set within limits. Refer to the Specifications section for values.

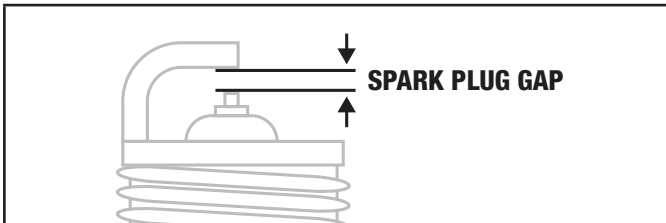

5. Refer to the spark plug section on the Specifications page when replacing the plug.
6. Carefully thread the plug into the engine.
7. Use the spark plug socket tool (included), or a 13/16 in. (21 mm) (not included) socket to install the plug.
8. Attach the spark plug wire to the plug.

Cleaning the Air Filter

1. Using your finger, pry the outer tab up slightly and lift the air filter cover above the tab lock position.

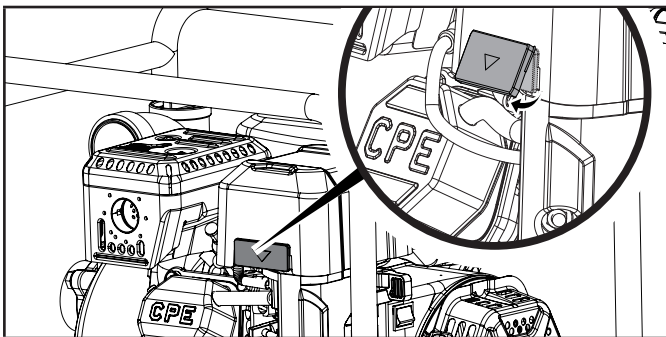

2. Remove both air filter cover and air filter element.

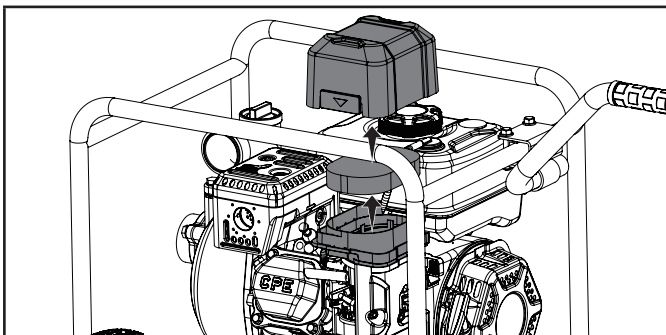

3. Wash in liquid detergent and water. Use a clean cloth.
4. Saturate in clean engine oil.
5. Squeeze in a clean, absorbent cloth to remove all excess oil.

6. Place the filter in the assembly.
7. Reattach the air filter cover. Attach the side closest to the gas tank then pivot down to close. Make sure air filter cover snaps in place.

Cleaning the Spark Arrestor

CAUTION

Failure to clean the spark arrestor will result in degraded engine performance.

NOTICE

Federal and local laws and administrative requirements indicate when and where spark arrestors are required. When ordered, spark arrestors are required for operation of this water pump in National Forest lands. In California, this water pump must not be used on any forest-covered land, brush-covered land, or grass-covered land unless the engine is equipped with a spark arrestor.

1. Allow the engine to cool completely before servicing the spark arrestor (if equipped).
2. Remove the screws holding the cover plate which retains the spark arrestor screen to the muffler.
3. Remove the spark arrestor screen.
4. Carefully remove the carbon deposits from the spark arrestor screen with a wire brush.

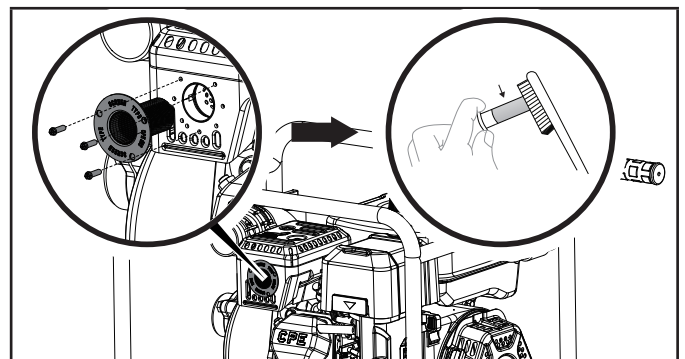

5. Replace the spark arrestor if it is damaged.
6. Position the spark arrestor on the muffler and attach with the screws.

Adjusting the Governor

⚠ WARNING

Tampering with the factory set governor will void your warranty.

The air-fuel mixture is not adjustable. Tampering with the governor can damage your water pump and will void your warranty. Contact our Technical Support Team at 1-888-373-8272 for all other service and/or adjustment needs.

Maintenance Schedule

Follow the service intervals indicated in the following maintenance schedule.

Service your water pump more frequently when operating in adverse conditions.

Contact our Technical Support Team at 1-888-373-8272 to locate the nearest Black Diamond certified service dealer for your water pump or engine maintenance needs.

EVERY 8 HOURS OR PRIOR TO EACH USE

- Check oil level
- Clean around air intake and muffler

FIRST 5 HOURS

- Change oil

EVERY 50 HOURS OR EVERY SEASON

- Clean air filter
- Change oil if operating under heavy load or in hot environments

EVERY 100 HOURS OR EVERY SEASON

- Change oil
- Clean/adjust spark plug
- Check/adjust valve clearance*
- Clean spark arrester
- Clean fuel tank and filter*

EVERY 250 HOURS

- Clean combustion chamber*

EVERY 3 YEARS

- Replace fuel line*

**To be performed by knowledgeable, experienced owners or Black Diamond certified service centers.*

STORAGE

Refer to the Maintenance section for proper cleaning instructions.

Water Pump Storage

1. Allow the water pump to cool completely before storage.
2. Turn off the fuel supply at the fuel valve.
3. Clean the water pump according to the instructions in the Maintenance section.
4. Drain the pump chamber thoroughly.
5. Once the pump is dry, spray WD-40 or similar product into the pump housing through all ports and drainage hole.
6. Store the unit in a clean, dry area out of direct sunlight.

Short Term Engine Storage (Up to 30 Days)

1. Allow the engine to cool completely before storage.
2. Clean engine according to the Maintenance section.
3. To extend the fuel storage life add a properly formulated fuel stabilizer to the fuel tank.
4. Ensure the fuel valve is in the “OFF” position.

Mid Term Engine Storage (30 Days – 1 year)

1. Add a properly formulated fuel stabilizer to the tank.
2. Run the engine for a few minutes so the treated fuel cycles through the fuel system and carburetor.
3. Turn the fuel valve to the “OFF” position.
4. Let the engine run until fuel starvation has stopped the engine. This usually takes a few minutes. The engine needs to cool completely before cleaning and storage.
5. Use a funnel (and appropriate hose if necessary) under the carburetor drain bolt to avoid spillage. Be sure to properly dispose of the drained gasoline according to local regulations or guidelines.

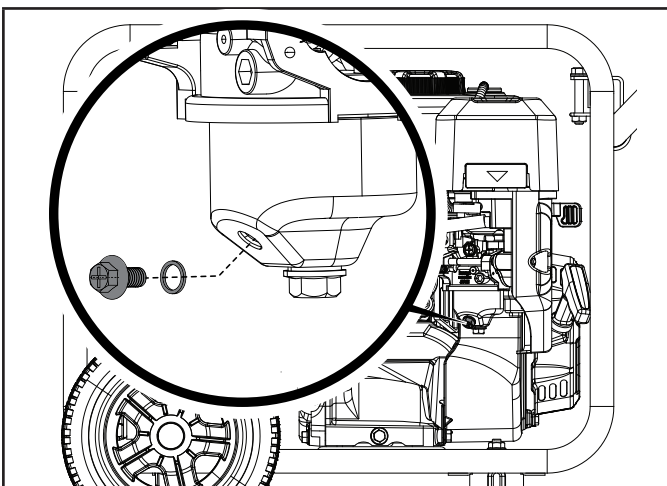

6. Clean the engine according to the Maintenance section.
7. Change the oil.
8. Remove the spark plug and pour about 1/2 oz. (14.9 mL) of oil into the cylinder. Crank the engine slowly to distribute the oil and lubricate the cylinder.
9. Reattach the spark plug.

Long Term Storage

⚠ WARNING

Never store the water pump indoors or next to appliances where there is a source of heat or open flame, spark or pilot light because they can ignite gasoline vapors. DO NOT store a water pump near fertilizer or any corrosive material. Even with an empty gas tank, gasoline vapors could ignite.

⚠ DANGER

Engine exhaust contains odorless and colorless carbon monoxide gas.

To avoid accidental or unintended ignition of the product during periods of storage, the following precautions should be followed:

- When storing the water pump for short or long periods of time make sure that the engine switch (where applicable) and the fuel valve are set in the “OFF” position.

🗨 NOTICE

Our engines work well with 10% or less ethanol blended gasoline. When using ethanol-gasoline blends there are some issues worth noting:

- Ethanol-gasoline blends can absorb more water than gasoline alone.
- These ethanol blends can eventually separate, leaving water or a watery goo in the tank, fuel valve and carburetor. The compromised gasoline can be drawn into the carburetor and cause damage to the engine and/or create potential hazards.
- If a fuel stabilizer is used, confirm that it is formulated to work with ethanol-gasoline blends.
- Any damages or hazards caused by using ethanol blended gasoline higher than 10% by volume, improperly stored gasoline, and/or improperly formulated stabilizers, are not covered by manufacturer’s warranty.

It is advisable to always shut off the gasoline supply and run the engine to starvation after each use. See Storage instructions for extended non-use.

Protect your water pump from freezing.

1. Apply all storage instructions from previous sections.
2. Make sure water pump is free of all water before storing for winter.
3. In order to prevent the pump from freezing you will need to insert RV antifreeze.
4. You will need approximately 6 oz. (177.4 mL) of RV antifreeze, a funnel, and approximately 12 in. (30.5 cm) of garden hose or equivalent.
5. Pour the antifreeze into the funnel connected to the pump inlet or priming cap (top) with a small hose, then pull on the recoil starter. Pull the recoil several times to circulate the antifreeze.

SPECIFICATIONS

Water Pump Specifications

Water Pump Type	Semi-trash
Port Diameter (in./cm)	2.0/5
Port Connection Type	NPT
Discharge Rate (gal/min - L/min)	159/600
Total Head (ft/m)	98/29.9
Suction Head (ft/m)	26/8
Solids Handling (in/mm)	0.6/14
Impeller Material	Cast Iron
Volute Material	Cast Iron
Self-Priming	Yes
Hose Kit Included	Yes
Discharge Hose Length (ft/m)	20/6.1
Suction Hose Length (ft/m)	12/3.7

Overall Dimensions

Net Weight	64 lb. (29 kg)
Length	24.8 in. (63 cm)
Width	21.3 in. (54 cm)
Height	19.2 in. (48.8 cm)

Engine Specifications

Model	YF168F-2-020
Displacement	196 cc
Type	4-Stroke OHV
Start Type	Recoil

Spark Plug Specifications

OEM Type	F6RTC
Replacement Type	NGK BPR6ES or equivalent
Gap	0.028-0.031 in. (0.7-0.8 mm)

Valve Specifications

Intake Clearance	0.004 - 0.006 in. (0.13-0.17 mm)
Exhaust Clearance	0.006 - 0.008 in. (0.18-0.22 mm)

Engine Oil Specifications

DO NOT OVERFILL.

Type	See chart below
Capacity	20.3 fl. oz (600 ml)

Recommended Engine Oil Type	
	10W-30
	5W-30
	10W-40
	5W-30 Full Synthetic
°F	-20 0 20 40 60 80 100 120
°C	-28.9 -17.8 -6.7 4.4 15.6 26.7 37.8 48.9
Ambient temperature	

NOTICE

Temperature will affect engine oil and engine performance. Change the type of engine oil used based on temperature shown in the "Recommended Engine Oil Type" table.

Fuel Specifications

Use unleaded gasoline with a minimum octane rating of 87 and an ethanol content of 10% or less by volume. DO NOT USE E15 or E85. DO NOT OVERFILL.

Gasoline Capacity	0.9 gal. (3.4 L)
-------------------------	------------------

Temperature Specifications

Starting Temperature Range (°F/°C)	5 to 104/-15 to 40
--	--------------------

NOTICE

An important message about temperature: Your product is designed and rated for continuous operation at ambient temperatures up to 104°F (40°C). When needed, it may be operated at temperatures ranging from 5°F (-15°C) to 122°F (50°C) for short periods of time. If exposed to temperatures outside this range during storage, it should be brought back within this range before operation. In any event, the product must always be operated outdoors, in a well-ventilated area and away from doors, windows and vents.

Problem	Cause	Solution
Pump will not start.	No fuel.	Allow engine to cool for 2 minutes, then fill fuel tank.
	Low oil.	Fill or check oil is to the proper level; place water pump on a flat, level surface.
	Faulty spark plug or cable	Replace spark plug or check spark plug cable is seated properly.
	Fuel valve lever is in the OFF position.	Turn the fuel valve lever to the ON position.
	Ignition switch is in the OFF position.	Turn the ignition switch to the ON position.
	Choke is in the wrong position.	Slide choke lever to the CHOKE position.
Pump will not pump.	Air leak in suction hose.	Make sure suction hose is double clamped at joints, clamps are tight, fittings have thread compound and are tight, with no nicks or cuts in hose.
	The suction and/or discharge line(s) may be blocked.	Check to see that the hoses and filter are in good working order.
	The end of the suction line is not submerged.	Increase its length, or move pump closer to source of liquid.
	Total head is too high for this pump to work against	Reduce total head or use a higher head pump.
Pump will not prime.	Allow more time	It may take up to 6 minutes to prime water up to the pump, depending on suction lift height.
	Hose clamps on inlet hose are not tight.	Even small pinhole leak can result in vacuum loss preventing pump from priming. Check hose clamps to ensure they are tight. Adjust clamp position if necessary.
	Excessive suction lift (*1).	Move the pump closer to liquid source.
	Excessive head lift.	Relocate pump so suction head is less than discharge head.
	Water not added through the top prime cap.	Review "Priming the Pump" section.
Priming takes a long time.	Suction line is quite long.	Move pump closer to source.
	Air pockets or leaks in the suction line.	Check the line for loose connections. Make sure suction hose is submerged.
Pump does not perform as well as it should.	Flow is restricted due to debris build-up.	Clean the hoses, fittings and filter.
	Insufficient submergence of the end of suction hose.	The end of the suction line must be submerged.
	Excessively worn impeller (*2).	Replace impeller.
	Seal is damaged (*3). Liquid will be leaking through the middle of the adapter.	Replace the seal.
	Air pockets or leaks in the suction hose.	Check suction hose.
	Clogged impeller.	Remove casing to clean out.
Pump loses prime.	Engine throttle is in SLOW position.	Move throttle to FAST position.
	Water level drops below the end of the suction line.	Increase length of suction line or move the pump closer to the water source.

Problem	Cause	Solution
Pump starts, but runs roughly.	Choke is in the wrong position.	Slide choke lever to the RUN position.
	Spark plug wire is loose.	Attach wire to spark plug securely.
	Faulty spark plug.	Replace spark plug.
	Fuel is contaminated (water, debris, etc.).	Allow engine to cool for 2 minutes, then drain fuel tank and carburetor. Fill tank with fresh fuel.
Pump shuts down during operation.	No fuel.	Allow engine to cool for 2 minutes, then fill fuel tank.
	Low oil sensor shuts down unit.	Make sure unit is on flat surface. Check oil level and add more if necessary.
<p>Excessive suction lift must take into consideration:</p> <ul style="list-style-type: none"> A. Size and length of pipe B. Pipe fitting C. Elevation above sea level <p>Including all of the above, we recommend that the total suction head not exceed 26 ft.</p>	<p>An excessively worn impeller is mainly caused from cavitation, which is caused by a number of situations, such as:</p> <ul style="list-style-type: none"> A. Restricted suction B. Excessive suction lift <p>The seal may be damaged due to:</p> <ul style="list-style-type: none"> A. Normal wear B. Overheating C. Pumping chemicals that this seal is not designed for. 	

For further technical support:

Technical Support Team
Toll Free 1-888-373-8272

WARRANTY

CHAMPION POWER EQUIPMENT
2 YEAR LIMITED WARRANTY

Warranty Qualifications

To register your product for warranty and FREE lifetime call center technical support please visit:

<https://www.championpowerequipment.com/register>

To complete registration you will need to include a copy of the purchase receipt as proof of original purchase. Proof of purchase is required for warranty service. Please register within ten (10) days from date of purchase.

Repair/Replacement Warranty

CPE warrants to the original purchaser that the mechanical and electrical components will be free of defects in material and workmanship for a period of two years (parts and labor) from the original date of purchase and 90 days (parts and labor) for commercial and industrial use. Transportation charges on product submitted for repair or replacement under this warranty are the sole responsibility of the purchaser. This warranty only applies to the original purchaser and is not transferable.

Do Not Return The Unit To The Place Of Purchase

Contact CPE's Technical Service and CPE will troubleshoot any issue via phone or e-mail. If the problem is not corrected by this method, CPE will, at its option, authorize evaluation, repair or replacement of the defective part or component at a CPE Service Center. CPE will provide you with a case number for warranty service. Please keep it for future reference. Repairs or replacements without prior authorization, or at an unauthorized repair facility, will not be covered by this warranty.

Warranty Exclusions

This warranty does not cover the following repairs and equipment:

Normal Wear

Products with mechanical and electrical components need periodic parts and service to perform well. This warranty does not cover repair when normal use has exhausted the life of a part or the equipment as a whole.

Installation, Use and Maintenance

This warranty will not apply to parts and/or labor if the product is deemed to have been misused, neglected, involved in an accident, abused, loaded beyond the product's limits, modified, installed improperly or connected incorrectly to any electrical component. Normal maintenance is not covered by this warranty and is not required to be performed at a facility or by a person authorized by CPE.

Other Exclusions

This warranty excludes:

- Cosmetic defects such as paint, decals, etc.
- Wear items such as filter elements, o-rings, etc.
- Accessory parts such as hoses, hose fittings, etc.
- Failures due to acts of God and other force majeure events beyond the manufacturer's control.
- Problems caused by parts that are not original Champion Power Equipment parts.

When applicable, this warranty does not apply to products used for prime power in place of a utility.

Limits of Implied Warranty and Consequential Damage

Champion Power Equipment disclaims any obligation to cover any loss of time, use of this product, freight, or any incidental or consequential claim by anyone from using this product. THIS WARRANTY AND THE ATTACHED U.S. EPA and/or CARB EMISSION CONTROL SYSTEM WARRANTIES (WHEN APPLICABLE) ARE IN LIEU OF ALL OTHER WARRANTIES, EXPRESS OR IMPLIED, INCLUDING WARRANTIES OF MERCHANTABILITY OR FITNESS FOR A PARTICULAR PURPOSE.

A unit provided as an exchange will be subject to the warranty of the original unit. The length of the warranty governing the exchanged unit will remain calculated by reference to the purchase date of the original unit.

This warranty gives you certain legal rights which may change from state to state or province to province. Your state or province may also have other rights you may be entitled to that are not listed within this warranty.

Contact Information

Address

Mid-States Distributing, LLC.
2800 Meacham Blvd.
Fort Worth, TX 76137 USA
www.black-diamond.com

Customer Service

Toll Free: 1-888-373-8272
info@black-diamond.com

*Except as otherwise stipulated in any of the following enclosed Emission Control System Warranties (when applicable) for the Emission Control System: U.S. Environment Protection Agency (EPA) and/or California Air Resources Board (CARB).

**CHAMPION POWER EQUIPMENT, INC. (CPE)
AND THE UNITED STATES ENVIRONMENT PROTECTION AGENCY (U.S. EPA)
EMISSION CONTROL SYSTEM WARRANTY**

Your Champion Power Equipment (CPE) engine complies with U.S. EPA emission regulations.

YOUR WARRANTY RIGHTS AND OBLIGATIONS:

The US EPA AND CPE are pleased to explain the Federal Emission Control Systems Warranty on your 2023 small off-road engine (SORE) and engine powered equipment. New engines and equipment must be designed, built and equipped, at the time of sale, to meet U.S. EPA regulations for small off-road engines (SORE). CPE warrants the emission control system on your small off-road engine (SORE) and equipment for the period of time listed below, provided there has been no abuse, neglect, unapproved modification, or improper maintenance of your equipment.

Your emission control system may include parts such as the carburetor, fuel-injection system, the ignition system, catalytic converter and fuel lines. Also included may be hoses, belts, connectors and other emission related assemblies. Where a warrantable condition exists, CPE will repair your small off-road engine (SORE) at no cost to you including diagnosis, parts and labor.

MANUFACTURER'S EMISSION CONTROL SYSTEM WARRANTY COVERAGE:

This emission control system is warranted for two years, subject to provisions set forth below. If, during the warranty period, an emission related part on your engine is defective in materials or workmanship, the part will be repaired or replaced by CPE.

OWNER WARRANTY RESPONSIBILITIES:

As the small off-road engine (SORE) owner, you are responsible for the performance of the required maintenance listed in your Owner's Manual. CPE recommends that you retain all your receipts covering maintenance on your small off-road engine (SORE), but CPE cannot deny warranty solely for the lack of receipts or for your failure to ensure the performance of all scheduled maintenance.

As the small off-road engine (SORE) owner, you should however be aware that CPE may deny you warranty coverage if your small, off-road engine (SORE) or a part has failed due to abuse, neglect, improper maintenance or unapproved modifications.

You are responsible for presenting your small off-road engine (SORE) to an Authorized CPE service outlet or alternate service outlet as described in (3)(f.) below, CPE dealer or CPE, Santa Fe Springs, Ca. as soon as a problem exists. The warranty repairs should be completed in a reasonable amount of time, not to exceed 30 days.

If you have any questions regarding your warranty rights and responsibilities, you should contact:

Champion Power Equipment, Inc.
Customer Service
12039 Smith Ave.
Santa Fe Springs, CA 90670
1-877-338-0999
tech@championpowerequipment.com

EMISSION CONTROL SYSTEM WARRANTY

The following are specific provisions relative to your Emission Control System (ECS) Warranty Coverage.

- 1. APPLICABILITY:** This warranty shall apply to 1997 and later model year small off-road engines (SORE). The ECS Warranty Period shall begin on the date the new engine or equipment is delivered to its original, end-use purchaser, and shall continue for 24 consecutive months thereafter.
- 2. GENERAL EMISSIONS WARRANTY COVERAGE**

CPE warrants to the original, end-use purchaser of the new engine or equipment and to each subsequent purchaser that each of its small off-road engines (SORE) is:

 - 2a. Designed, built and equipped so as to conform to U.S. EPA emissions standards for spark-ignited engines at or below 19 kilowatts.
 - 2b. Free from defects in materials and workmanship that cause the failure of a warranted part to be identical in all material respects to the part as described in the engine manufacturer's application for certification for a period of two years.
- 3. THE WARRANTY ON EMISSION-RELATED PARTS WILL BE INTERPRETED AS FOLLOWS:**
 - 3a. Any warranted part that is not scheduled for replacement as required maintenance in the Owners Manual shall be warranted for the ECS Warranty Period. If any such part fails during the ECS Warranty Period, it shall be repaired or replaced by CPE according to Subsection "d" below. Any such part repaired or replaced under the ECS Warranty shall be warranted for any remainder of the ECS Warranty Period.
 - 3b. Any warranted, emissions-related part which is scheduled only for regular inspection as specified in the Owners Manual shall be warranted for the ECS Warranty Period. A statement in such written instructions to the effect of "repair or replace as necessary", shall not reduce the ECS Warranty Period. Any such part repaired or replaced under the ECS Warranty shall be warranted for the remainder of the ECS Warranty Period.
 - 3c. Any warranted, emissions-related part which is scheduled for replacement as required maintenance in the Owner's Manual shall be warranted for the period of time prior to the first scheduled replacement point for that part. If the part fails prior to the first scheduled replacement, the part shall be repaired or replaced by CPE according to Subsection "d" below. Any such emissions-related part repaired or replaced under the ECS Warranty, shall be warranted for the remainder of the ECS Warranty Period prior to the first scheduled replacement point for such emissions-related part.
 - 3d. Repair or replacement of any warranted, emissions-related part under this ECS Warranty shall be performed at no charge to the owner at a CPE Authorized Service Outlet.
 - 3e. The owner shall not be charged for diagnostic labor which leads to the determination that a part covered by the ECS Warranty is in fact defective, provided that such diagnostic work is performed at a CPE Authorized Service Outlet.
 - 3f. CPE shall pay for covered emissions warranty repairs at non-authorized service outlets under the following circumstances:
 - i. The service is required in a population center with a population over 100,000 according to U.S. Census 2000 without a CPE Authorized Service Outlet AND
 - ii. The service is required more than 100 miles from a CPE Authorized Service Outlet. The 100 mile limitation does not apply in the following states: Alaska, Arizona, Colorado, Hawaii, Idaho, Montana, Nebraska, Nevada, New Mexico, Oregon, Texas, Utah and Wyoming.
 - 3g. CPE shall be liable for damages to other original engine components or approved modifications proximately caused by a failure under warranty of an emission-related part covered by the ECS Warranty.
 - 3h. Throughout the ECS Warranty Period, CPE shall maintain a supply of warranted emission-related parts sufficient to meet the expected demand for such emission-related parts.
 - 3i. Any CPE Authorized and approved emission-related replacement part may be used in the performance of any ECS Warranty maintenance or repair and will be provided without charge to the owner. Such use shall not reduce CPE's warranty obligation.
 - 3j. Unapproved add-on or modified parts may not be used to modify or repair a CPE engine. Such use voids this ECS Warranty and shall be sufficient grounds for disallowing an ECS Warranty claim. CPE shall not be liable hereunder for failures of any warranted parts of a CPE engine caused by the use of such an unapproved add-on or modified part.

EMISSION-RELATED PARTS INCLUDE THE FOLLOWING: (using those portions of the list applicable to the engine)

Systems covered by this warranty	Parts Description
Fuel Metering System	Fuel regulator, Carburetor and internal parts
Air Induction System	Air cleaner, Intake manifold
Ignition System	Spark plug and parts, Magneto ignition system
Exhaust System	Exhaust manifold, catalytic converter
Miscellaneous Parts	Tubing, Fittings, Seals, Gaskets, and Clamps associated with these listed systems.
Evaporative Emissions	Fuel Tank, Fuel Cap, Fuel Line (for liquid fuel and fuel vapors), Fuel Line Fittings, Clamps, Pressure Relief Valves, Control Valves, Control Solenoids, Electronic Controls, Vacuum Control Diaphragms, Control Cables, Control Linkages, Purge Valves, Gaskets, Vapor Hoses, Liquid/Vapor Separator, Carbon Canister, Canister Mounting Brackets, Carburetor Purge Port Connector

TO OBTAIN WARRANTY SERVICE:

You must take your CPE engine or the product on which it is installed, along with your warranty registration card or other proof of original purchase date, at your expense, to any Champion Power Equipment dealer who is authorized by Champion Power Equipment, Inc. to sell and service that CPE product during his normal business hours. Alternate service locations defined in Section (3)(f.) above must be approved by CPE prior to service. Claims for repair or adjustment found to be caused solely by defects in material or workmanship will not be denied because the engine was not properly maintained and used.

If you have any questions regarding your warranty rights and responsibilities, or to obtain warranty service, please write or call Customer Service at Champion Power Equipment, Inc.

Champion Power Equipment, Inc.
12039 Smith Ave.
Santa Fe Springs, CA 90670
1-877-338-0999
Attn.: Customer Service
tech@championpowerequipment.com