



OPERATOR'S MANUAL

MODEL #BD201258
38 TON FULL BEAM LOG SPLITTER



  1-888-376-7375

or visit black-diamond.com

READ AND SAVE THIS MANUAL. This manual contains important safety precautions which should be read and understood before operating the product. Failure to do so could result in serious injury. This manual should remain with the product.

Specifications, descriptions and illustrations in this manual are as accurate as known at the time of publication, but are subject to change without notice.

TABLE OF CONTENTS

Introduction	3	Maintenance	21
Safety Definitions	3	Cleaning the Log splitter	21
Important Safety Instructions	4	Changing the Engine Oil	21
Fuel Safety	6	Cleaning and Adjusting the Spark Plug(s)	21
Training Instructions	7	Cleaning the Air Filter	21
Preparation	7	Changing the Hydraulic Oil	21
Operation	8	Maintenance Schedule	22
Maintenance	8	Storage	24
Safety and Dataplate Labels	9	Log Splitter Storage	24
Safety Symbols	10	Engine Storage	24
Controls and Features	12	Specifications	25
Log Splitter	12	Log Splitter Specifications	25
Parts Included	13	Hydraulic Oil System	25
Assembly	14	Engine Specifications	25
Open Shipping Crate	14	Oil Specifications	25
1) Install the Wheels	14	Fuel Specifications	25
2) Install the Tow Bar	14	Important Message About Temperature	25
3) Install the Beam	14	Troubleshooting	26
4) Install the Engine	15	Warranty	27
5) Install the Hoses	15	Warranty Qualifications	27
6) Install the Log Catchers	16	Repair/Replacement Warranty	27
Add Engine Oil	17	Do Not Return The Unit To The Place Of Purchase	27
Add Fuel	17	Warranty Exclusions	27
Add Hydraulic Oil	17	Other Exclusions	27
Operation	18	Limits of Implied Warranty and Consequential Damage	27
Before Each Use Inspect the Log Splitter	18	Contact Information	27
Changing Beam from Horizontal to Vertical Orientation	18		
Towing Log Splitter Safety	19		
Log Splitter Location	19		
Starting the Engine	19		
Stopping the Engine	20		
Log Splitter Operation	20		
Operation at High Altitude	20		

FOR PARTS BREAKDOWN

Search by model number at
championpowerequipment.com

INTRODUCTION

Congratulations on your purchase of a Black Diamond product. Black Diamond designs, builds, and supports all of our products to strict specifications and guidelines. With proper product knowledge, safe use, and regular maintenance, this product should bring years of satisfying service.

Every effort has been made to ensure the accuracy and completeness of the information in this manual at the time of publication, and we reserve the right to change, alter and/or improve the product and this document at any time without prior notice.

Black Diamond highly values how our products are designed, manufactured, operated, and serviced as well as providing safety to the operator and those around the log splitter. Therefore, it is **IMPORTANT** to review this product manual and other product materials thoroughly and be fully aware and knowledgeable of the assembly, operation, dangers and maintenance of the product before use. Fully familiarize yourself, and make sure others who plan on operating the product fully familiarize themselves too, with the proper safety and operation procedures before each use. Please always exercise common sense and always err on the side of caution when operating the product to ensure no accident, property damage, or injury occurs. We want you to continue to use and be satisfied with your Black Diamond product for years to come.

When contacting Black Diamond/Champion Power Equipment about parts and/or service, you will need to supply the complete model and serial numbers of your product. Transcribe the information found on your product's dataplate label to the table below.

BLACK DIAMOND TECHNICAL SUPPORT TEAM

1-888-376-7375

MODEL NUMBER

BD201258

SERIAL NUMBER

DATE OF PURCHASE

PURCHASE LOCATION

SAFETY DEFINITIONS

The purpose of safety symbols is to attract your attention to possible dangers. The safety symbols, and their explanations, deserve your careful attention and understanding. The safety warnings do not by themselves eliminate any danger. The instructions or warnings they give are not substitutes for proper accident prevention measures.

DANGER

DANGER indicates a hazardous situation which, if not avoided, will result in death or serious injury.

WARNING

WARNING indicates a hazardous situation which, if not avoided, could result in death or serious injury.

CAUTION

CAUTION indicates a hazardous situation which, if not avoided, could result in minor or moderate injury.

NOTICE

NOTICE indicates information considered important, but not hazard-related (e.g., messages relating to property damage).

IMPORTANT SAFETY INSTRUCTIONS

⚠ WARNING

Cancer and Reproductive Harm – www.P65Warnings.ca.gov

⚠ DANGER

Engine exhaust contains carbon monoxide, a colorless, odorless, poison gas. Breathing carbon monoxide will cause nausea, dizziness, fainting or death. If you start to feel dizzy or weak, move to fresh air immediately.

Operate log splitter outdoors only in a well ventilated area.

DO NOT operate the log splitter inside any building, including garages, basements, crawlspaces, sheds, or enclosure.

DO NOT allow exhaust fumes to enter a confined area through windows, doors, vents or other openings.

⚠ DANGER

Using an engine indoors **CAN KILL YOU IN MINUTES**. Engine exhaust contains carbon monoxide. This is a poison you cannot see or smell.

NEVER use inside a home or garage, **EVEN IF** doors and windows are open.

ONLY use **OUTSIDE** and far away from windows, doors, and vents.

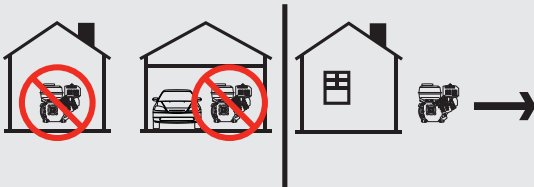

⚠ WARNING

Although the log splitter contains a spark arrester, maintain a minimum distance of 5 ft. (1.5 m) from dry vegetation to prevent fires.

⚠ WARNING

Sparks can result in fire or electrical shock.

When servicing the engine:

Disconnect the spark plug wire and place it where it cannot contact the plug.

DO NOT check for spark with the plug removed.

Use only approved spark plug testers.

⚠ WARNING

Running engines produce heat. Severe burns can occur on contact. Combustible material can catch fire on contact.

DO NOT touch hot surfaces.

Avoid contact with hot exhaust gases.

Allow equipment to cool before touching.

Maintain at least 3 ft. (91.4 cm) of clearance on all sides to ensure adequate cooling.

⚠ WARNING

Crush Hazard

Wedge can cut through skin and break bones. Keep all limbs away from wedge and endplate.

⚠ WARNING

Projectile Hazard

Pieces of log may be ejected from the splitter while operating. Always wear ANSI approved safety glasses when operating. Be alert.

⚠ WARNING

Keep operator work zone clear of debris while working to ensure safe footing.

⚠ DANGER

Skin Injection Hazard.

Hydraulic oil escaping under high pressure can penetrate skin and cause serious bodily injury. In the event that hydraulic oil may penetrate the skin and to avoid serious infections such as gangrene, seek proper medical attention immediately.

⚠ WARNING

Always make sure all hydraulic oil connections are tightly secured and hydraulic hoses are in good condition, no cuts, tears, or damage before applying pressure to the system.

IMPORTANT SAFETY INSTRUCTIONS

⚠ WARNING

Always keep hands and body parts away from nozzles or pinholes that could eject hydraulic oil under high pressure in the event of an oil leak.

NEVER use bare hands to search for leaks. Leaks can be detected by using cardboard, paper or scrap wood over the suspected area.

⚠ WARNING

Towing Hazard

Always check with your local municipality, state or provincial regulations regarding towing, lights and licensing before towing your log splitter on public roads.

BEFORE towing, review all safety warnings in your towing vehicle manual. Drive safely. Be aware of the added length of the log splitter.

NEVER ride or transport cargo on the log splitter.

DO NOT exceed the maximum 45 MPH (72 KM/H) towing speed.

⚠ WARNING

Before removing the pin installed on the front support leg, make sure the hitch is installed onto the vehicle. Releasing the pin before will cause support leg to slide up and possibly cause injury.

⚠ WARNING

Rapid retraction of the starter cord will pull hand and arm towards the engine faster than you can let go. Broken bones, fractures, bruises or sprains could result.

When starting engine, pull the starter cord slowly until resistance is felt and then pull rapidly to avoid kickback.

⚠ CAUTION

Parts of the hydraulic circuit (cylinder, pump, valve-body, hoses) can become very hot during operation.

⚠ WARNING

Improper treatment or use of the log splitter can damage it, shorten its life and void your warranty.

ALWAYS use the log splitter for its intended use.

Operate only on level surfaces.

DO NOT expose log splitter to excessive moisture, dust, or dirt.

DO NOT allow any material to block the cooling slots.

DO NOT use the engine if:

- Equipment sparks, smokes or emits flames
- Equipment vibrates excessively

IMPORTANT SAFETY INSTRUCTIONS

Fuel Safety

⚠ DANGER

GASOLINE AND GASOLINE VAPORS ARE HIGHLY FLAMMABLE AND EXPLOSIVE.

Fire or explosion can cause severe burns or death.

Gasoline and gasoline vapors:

- Gasoline vapors are highly flammable and explosive.
- Gasoline vapors can cause a fire or explosion if ignited.
- Gasoline is a liquid fuel and the resulting gasoline vapors can ignite and cause a fire or explosion.
- Gasoline is a skin irritant and needs to be cleaned up immediately if spilled on skin or clothes.
- Gasoline has a distinctive odor, this will help detect potential leaks quickly.
- In any petroleum gas fire, flames should not be extinguished unless by doing so the fuel supply valve can be turned OFF. This is because if a fire is extinguished and a supply of fuel is not turned OFF, then an explosion hazard could be created.
- Gasoline vapors expand and contract with ambient temperatures. Never fill the gasoline tank past the red FULL indicator on the fuel filter, as gasoline vapors need room to expand if temperatures rise.

⚠ WARNING

When adding or removing gasoline:

Do not light or smoke cigarettes.

Always stop the engine and allow to cool for a minimum of two minutes before refueling.

Always loosen gasoline cap slowly to release vapor pressure and to keep fuel from escaping around the gasoline cap.

Always replace and tighten the gasoline cap securely after fueling.

Never remove the gasoline cap or add gasoline while the engine is running or when the engine is hot.

Only fill or drain gasoline outdoors in a well-ventilated area.

Do not pump gasoline directly into the log splitter at the gas station.

Always store gasoline in an EPA/CARB compliant container or to transfer the gasoline to the log splitter.

Do not overfill the gasoline tank.

Always keep gasoline away from sparks, open flames, pilot lights, heat and other sources of ignition.

⚠ WARNING

When starting the log splitter:

Do not attempt to start a damaged log splitter.

Always check that the gasoline cap, air filter, spark plug, fuel lines and exhaust system are properly in place.

Always allow spilled gasoline to evaporate fully before attempting to start the engine.

Always be certain that the log splitter is resting firmly on level ground.

⚠ WARNING

When operating the log splitter:

Do not move or tip the log splitter during operation.

⚠ WARNING

When transporting or servicing the log splitter:

Always check that the fuel valve is in the OFF position and the gasoline tank is empty.

Disconnect the spark plug wire.

⚠ WARNING

When storing the log splitter:

Store away from sparks, open flames, pilot lights, heat and other sources of ignition.

Do not store log splitter or gasoline near furnaces, water heaters, or any other appliances that produce heat or have automatic ignitions.

⚠ DANGER

Never place a gasoline container, gasoline tank, or any combustible material in the path of the exhaust stream during operation of the engine.

⚠ WARNING

Never use a gasoline container, gasoline tank, or any other fuel item that is broken, cut, torn or damaged.

Training Instructions

⚠ CAUTION

1. Read the Operator's Manual completely before attempting to use this log splitter.
2. Do not allow anyone to operate your log splitter who has not read the Operator's Manual or has not been instructed on the safe use of the log splitter.
3. Never allow children or untrained adults to operate this machine.
4. Accidents occur when more than one (1) person operates the log splitter. If a helper is assisting in loading logs to be split, never actuate controls until helper is clear of the area.
5. Never transport cargo on the log splitter or ride on the machine.
6. High fluid pressures develop in hydraulic log splitters. Pressurized hydraulic fluid escaping through a pin hole opening can puncture skin and cause severe infections or blood poisoning. Therefore, these instructions should be followed at all times.
 - Do not operate the unit with frayed, kinked, cracked or damaged hoses, fittings, or tubing.
 - Stop the engine and relieve hydraulic system pressure before changing or adjusting fittings, hoses, tubing, or other system components.
 - Do not adjust the pressure settings of the pump or valve.
 - Do not check for leaks with your hand. Leaks can be detected by passing cardboard or wood over the suspected area. Look for discoloration. If injured by escaping fluid, see a doctor at once. Serious infection or reaction can develop if proper medical treatment is not administered immediately.
7. Keep the operator zone and adjacent area clear for safe, secure footing.
8. Your log splitter is equipped with an internal-combustion engine and is not intended for use near any unapproved regulated and controlled forest, brush, or grass covered land. Always check with your local municipality, state and federal regulations prior to use.
9. Log splitters should be used only for splitting wood.

Preparation

⚠ CAUTION

1. Be thoroughly familiar with all controls and with proper use of the equipment.
2. Safety Gear:
 - Always wear safety shoes or heavy boots when operating the machine.
 - Always wear safety glasses or goggles when operating the machine.
 - Never wear jewelry or loose-fitting clothing that might become entangled in moving or rotating parts of the machine.
3. Make sure the splitter is on a level surface. Block tires and ensure support leg is secure to prevent unintended movement of the log splitter during operation.
 - Always operate the splitter from the manufacturer's indicated operator zone.
4. Logs to be split on ram-type units should be cut as squarely as possible.

IMPORTANT SAFETY INSTRUCTIONS

Operation

⚠ CAUTION

1. Before starting this log splitter, review all safety instructions. Failure to follow these instructions may result in serious injury to the operator or bystanders.
2. Be sure to confirm all hose clamp connections are tight before each use. It is possible for clamp connections to vibrate loose over time.
3. Never leave the machine unattended with the power source operating.
4. Never operate the machine when under the influence of alcohol, drugs or medication.
5. The machine owner should instruct all operators in safe log splitter operation.
6. Always operate the log splitter with all safety equipment in place and all controls properly adjusted for safe operation.
7. Always operate the log splitter at manufacturer's recommended speed.
8. Always keep hands and feet clear of moving parts.
9. When loading a ram-type log splitter, place your hands on the sides of the log, not the ends. Never place your hands or any part of your body between a log and any part of the log splitter.
10. On ram-type log splitters, never attempt to split more than one (1) log at a time unless the ram has been fully extended and a second log is needed to complete the separation of the first log.
11. On ram-type log splitters on which the logs are not cut square, the longest portion of the log should be rotated down and the most square end placed against the ram.
12. Always split logs with the grain of the wood.
13. Never split perpendicular to the grain of the wood.
14. Use only your hand to operate the log splitter controls.
15. Never add fuel to a running or hot engine.
16. Always turn the engine off and wait a minimum of 2 minutes to cool engine before removing gasoline cap prior to refueling.

Maintenance

⚠ CAUTION

1. Always shut off the power source while repairing or adjusting the splitter except as recommended by the manufacturer.
2. Clean debris and chaff from the engine cylinder, cylinder head fins, recoil starter cover, and muffler areas. The engine is equipped with a spark arrestor muffler, clean and inspect it regularly (follow manufacturer's service instructions). Replace, if damaged.
3. Check to be sure all nuts and bolts are tight to assure the equipment is in safe working condition before next operation.

IMPORTANT SAFETY INSTRUCTIONS

Safety and Dataplate Labels

These labels warn you of potential hazards that can cause serious injury. Read them carefully.

If a label comes off or becomes hard to read, contact Technical Support Team for possible replacement.

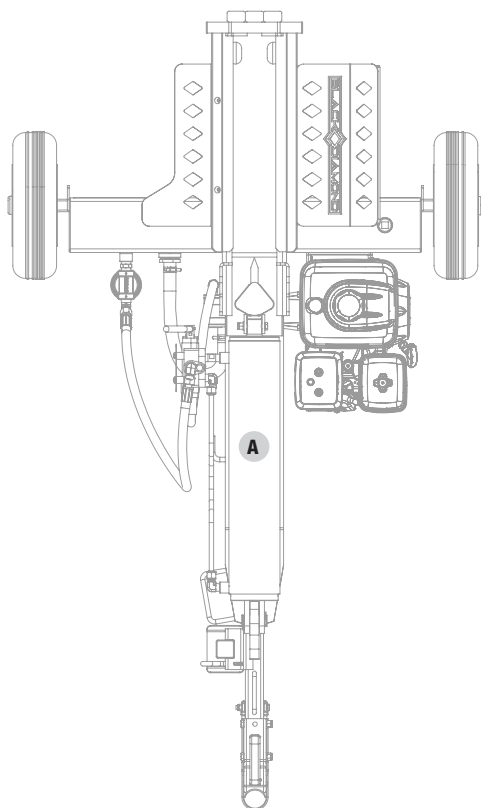

Top

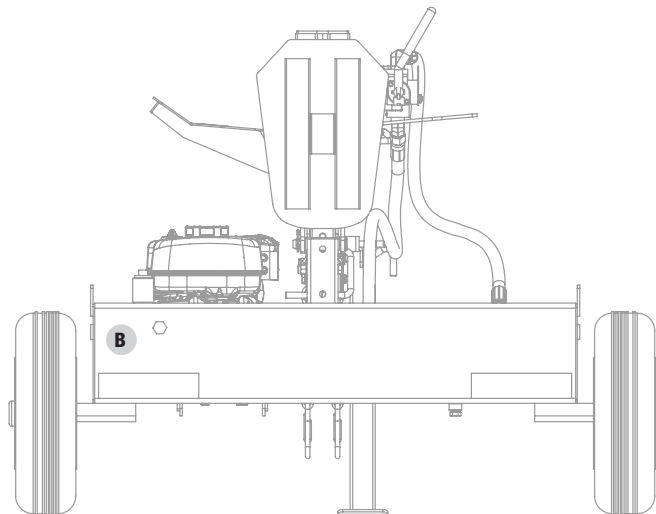









Back

	LABEL	DESCRIPTION
A		Safety Symbols
B		Dataplate









IMPORTANT SAFETY INSTRUCTIONS

Safety Symbols

Some of the following symbols may be used on this product. Please study them and learn their meaning. Proper interpretation of these symbols will allow you to more safely operate the product.

SYMBOL	MEANING
	Read Operator's Manual. To reduce the risk of injury, user must read and understand operator's manual before using this product.
	Eye and Ear Protection. Always wear safety goggles or safety glasses with side shields, and as necessary a full face-shield as well as full ear protection when operating this product.
	Footwear. Always wear safety shoes or heavy boots when operating the machine.
	Gloves. Always wear nonslip, heavy-duty protective gloves when operating this product.
	Safety Alert. Precautions that involve your safety.
	Risk of Fire. Fuel and its vapors are extremely flammable and explosive. Fire can cause severe burns or death. Do not add fuel while the product is operating or still hot.
	Skin Injection Hazard. High pressure hydraulic oil can inject under your skin. Make sure all fittings are tightly secure before applying pressure. Relieve system pressure before servicing.
	Always keep hands away from the wedge and the ram. Moving parts can crush or cut.

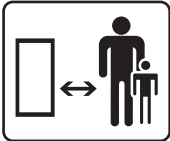
IMPORTANT SAFETY INSTRUCTIONS

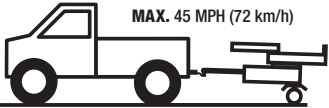
SYMBOL	MEANING
	<p>Always keep feet away from the wedge and the ram. Moving parts can crush or cut.</p>
	<p>Hot Surface. To reduce the risk of injury or damage, avoid contact with any hot surface</p>
	<p>Open Flame alert. Fuel and its vapors are extremely flammable and explosive. Keep fuel away from smoking, open flames, sparks, pilot lights, heat, and other ignition sources.</p>
	<p>Hold logs on sides when loading. Keep hands and feet away from cylinder, wedge, and partially split logs.</p>
	<p>Never place hands or any part of the body between a log and any part of the log splitter. Do not split logs against the grain. Split logs end to end in the direction of the grain only.</p>
	<p>Toxic Fumes. The engine exhaust from this product contains chemicals known to the state of California to cause cancer and birth defects and other reproductive harm.</p> <p>Risk of Asphyxiation. This engine emits carbon monoxide, an odorless, colorless poison gas. Breathing carbon monoxide can cause nausea, fainting or death. Use only in a well ventilated area.</p>
	<p>Clearance. Keep all objects including others at least 10 feet (3m) from this machine. Only one person should operate the log splitter and load the logs</p>
	<p>Never operate on an incline. Make sure the splitter is on a level surface. Block tires and ensure support leg is secure to prevent unintended movement of the log splitter during operation.</p>
	<p>DO NOT exceed the maximum 45 MPH (72 KM/H) towing speed.</p> <p>Always check all local, state or provincial regulations regarding towing, licensing and lights before towing your log splitter. Review towing safety warnings in your towing vehicle manual.</p> <p>In most states towing on public streets is either prohibited or would require further licensing or modifications. Please check with your local, state, or provincial authorities regarding regulations, restrictions and registration.</p> <p>Any modifications required to meet these laws are the responsibility of the purchaser.</p>

CONTROLS AND FEATURES

Read this operator's manual before operating your log splitter. Familiarize yourself with the location and function of the controls and features. Save this manual for future reference.

Log Splitter

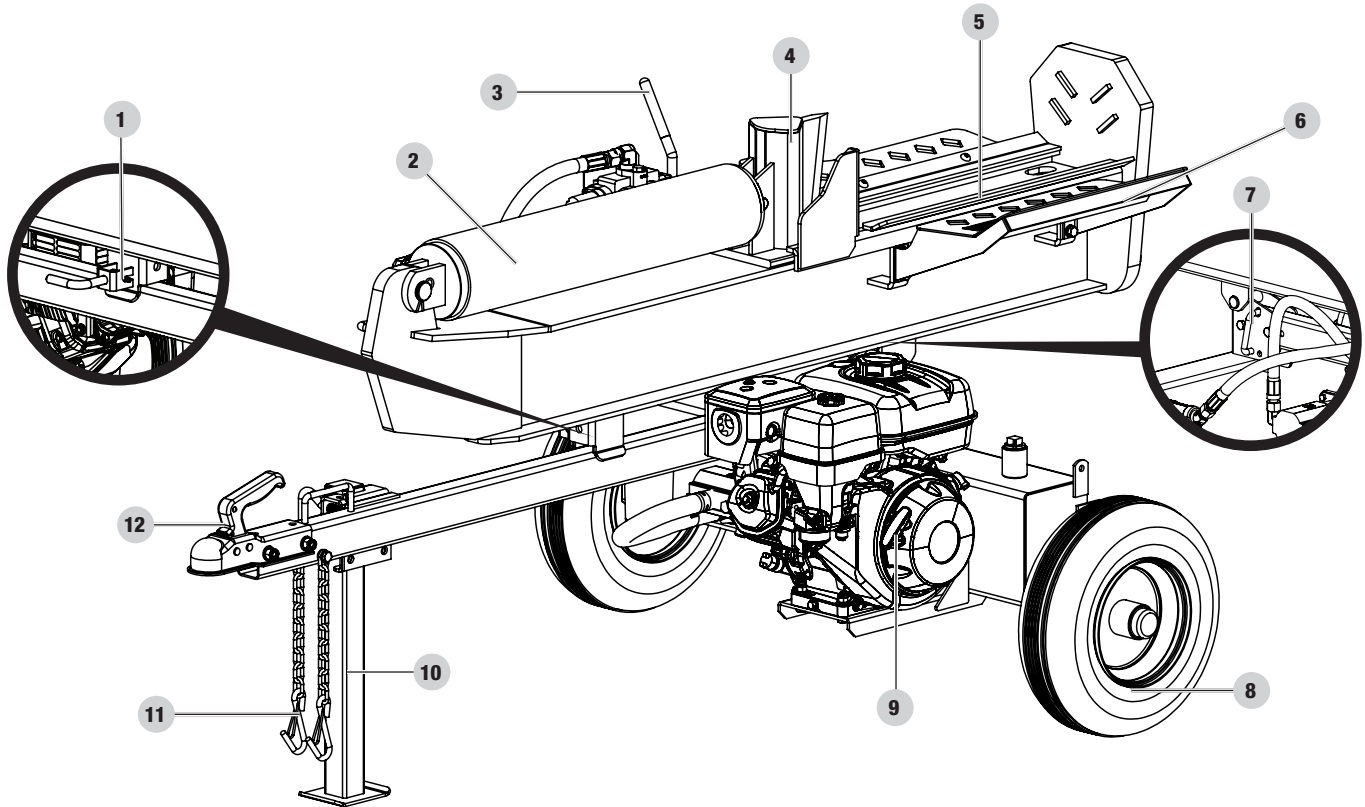

1. **Auto-Lock Horizontal Beam Lock** – Secures the beam in the horizontal position.
2. **Hydraulic Cylinder** – 5 in. bore (12.7 cm) × 23 in. (58.4 cm) stroke. MAX to 3900 psi.
3. **Control Valve Handle** – Controls the movement of the cutting wedge.
4. **Wedge**
5. **Log Cradle** – Prevents logs from rolling off beam.
6. **Log Catchers**
7. **Quick-Lock Vertical Beam Lock** – Secures the beam in the vertical position.
8. **Tires** – Maximum travel speed is 45 MPH (72 KM/H).
9. **Engine** – 270cc, OHV.
10. **Support Leg** – Supports log splitter while operating. Raise leg for towing.
11. **Safety Chains** – For use while towing.
12. **2 in. (5.1 cm) Ball Coupler** – For towing the log splitter behind your vehicle.

Parts Included

Part	Part Qty.	Hardware Needed	Hardware Qty.	Tool Needed
Wheels	2	Castle Nut	2	1x 30mm open-end wrench
		Cotter Pin Ø4 × 32	2	Needle nose pliers
		Axle Cap	2	Mallet
Tow Bar	1	Bolt M12x80	2	1x 18mm wrench or socket
		Nut M12	2	1x 19mm wrench or socket
		Flat Washer Ø12	2	
Beam	1	Hitch Pin	1	
		R-Pin	1	
Engine	1	Bolt M10x45	4	1x 16mm wrench
		Lock Nut M10	4	1x 17mm wrench
		Flat Washer Ø10	4	
Suction Hose	1	Spring Loaded Hose Clamp	2	Clamp Tool
High Pressure Hose	1	"O" Ring Ø10 x 2.65	1	1x 27mm open-end wrench
Oil Return Hose	1			1x 27mm open-end wrench
Log Catchers	2	Bolt M10x20	4	1x 16mm wrench or socket
		Bolt M10x30	2	1x 6mm allen wrench
		Nut M10	2	1x 17mm wrench
		Lock Washer Ø10	6	
		Flat Washer Ø10	6	

Accessories

- Spark Plug Wrench
- Oil Funnel

ASSEMBLY

If your log splitter is already assembled, skip the assembly instructions in this manual.

If unassembled, please read and follow these instructions.

If you have any questions regarding the assembly of your log splitter, call our Technical Support Team at 1-888-376-7375. Please have your serial number and model number available.

Open Shipping Crate

1. Set the shipping crate on a solid, flat surface
2. Carefully cut the shipping bands and remove lid of shipping crate.
3. Locate all hardware before beginning assembly.

1) Install the Wheels

1. Remove the two plastic shipping caps from the wheel hubs.
2. Slide the wheel onto the axle.
3. Be sure the tire valve stem is facing out.
4. Thread the castle nut on the axle and tighten by hand. Use a wrench to tighten another $\frac{1}{4}$ turn.
5. Spin the wheel to distribute the bearing grease.
6. Loosen the castle nut and re-tighten by hand.
7. Install the cotter pin through the axle and castle nut.
8. Wheel should spin freely but when grasped on both sides, should not move from side to side.
9. Install the axle cap using a soft-faced mallet or hammer and wood block.
10. Repeat for the other wheel.

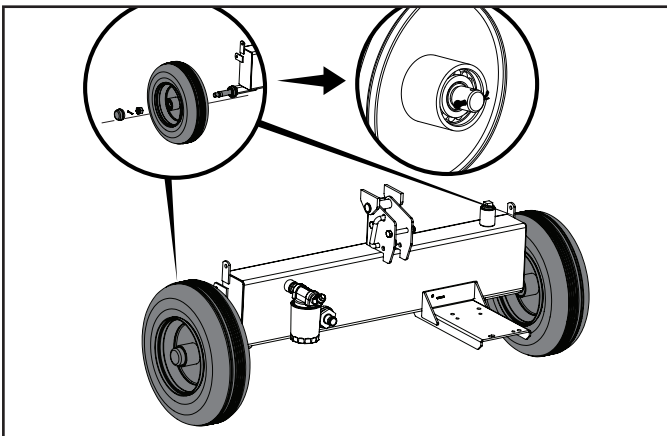

NOTICE

Keep dirt and debris away from the wheel bearings during assembly.

CAUTION

Over-tightening the castle nut will cause the bearings to run hot and fail prematurely.

2) Install the Tow Bar

Attach the tow bar to the bracket on top of the hydraulic oil tank with two M12 \times 80 bolts, \varnothing 12 flat washers and M12 lock nuts.

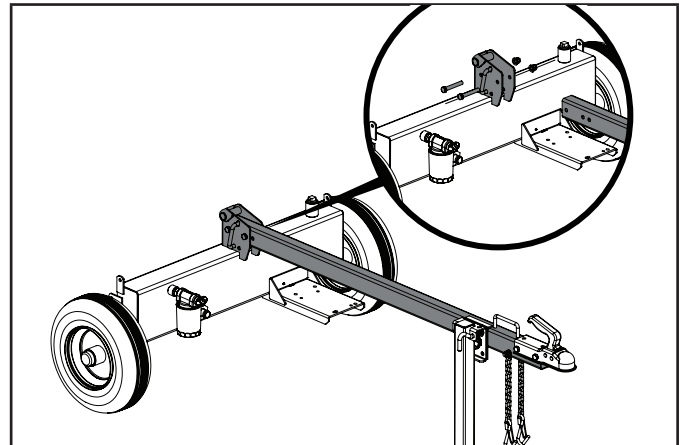

3) Install the Beam

1. Stand the beam vertical on the foot plate.
2. Roll the tank into position so the pivot holes of the tank and beam are aligned.
3. Insert the Pin and secure it with the R-pin.

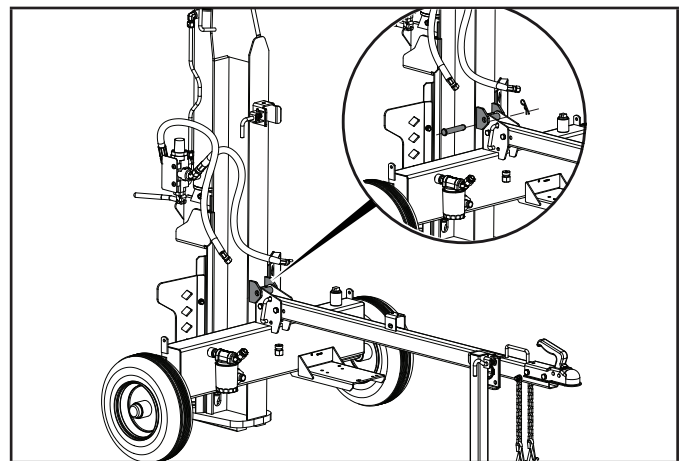

WARNING

The beam is extremely heavy and should only be handled with 2 or more people. DO NOT try and lift or handle the beam without assistance.

4) Install the Engine

1. Place the engine on the engine mounting platform with the recoil cover facing outward towards the wheel and align the 4 holes on the engine base with the holes in the engine platform.

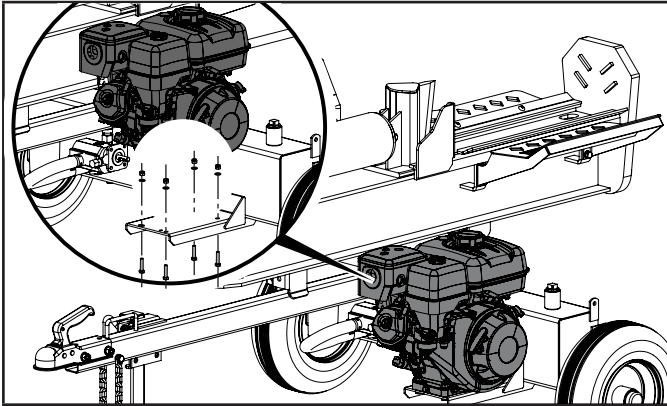

2. Install a M10 × 45 bolt up through the hole on the engine platform and through the hole on the engine base.
3. Place a washer on the M10 × 45 bolt and thread a M10 nylon lock nut onto the bolt and tighten securely. Tighten to 12 lbf-ft – 15 lbf-ft (16-20 Nm) or fully, then a 1/4 turn further.
4. Repeat steps 2 and 3 for the remaining bolts, washers and lock nuts.

5) Install the Hoses

⚠ CAUTION

Red shipping plugs must be removed from hydraulic pump prior to installing hoses.

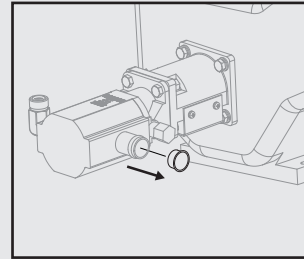

Hydraulic pump may contain residual oil from testing procedures during production. We recommend using an oil tray under the pump before removing the shipping plugs.

🗨 NOTICE

Oil Inlet (High Pressure) and Oil Return Hoses

Some hoses may be preassembled by the factory, check your hoses per below instructions to ensure proper assembly.

- These hoses are black and have swivel nuts on both ends.
- The Oil Inlet Hose sends hydraulic oil from the pump to the control valve/cylinder.
- The Oil Return Hose returns hydraulic oil from the control valve/cylinder to the tank.
- Hose connections do NOT require thread seal tape. The O-ring seals against the face of the fittings on the pump and hose.

Suction Hose

- This is the clear hose that connects the hydraulic tank to the pump inlet.
- Secure both ends of hose with hose clamps.

Suction Hose

1. Using the provided spring loaded hose clamps, connect one end of the clear oil hose to the hydraulic oil tank and the other end to the pump inlet on the pump. Using a pair of pliers, squeeze the tabs on the spring loaded hose clamps together to open them up and slide over the end of the clear suction hose and mounting fitting and release the pliers to lock the clamps into place.

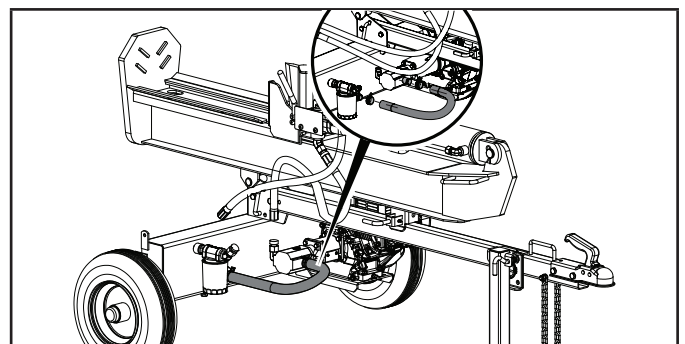

Oil Inlet (High Pressure) Hose

2. Place the provided o-ring into the pump outlet fitting as shown. Make sure the o-ring is properly seated in the inner groove of the fitting.
3. Thread the loose end of the high pressure hydraulic hose onto the pump outlet.
4. Securely tighten the hose fitting with a 27mm wrench. Tighten to 44 lbf-ft - 52 lbf-ft (59.7-70.5 Nm).

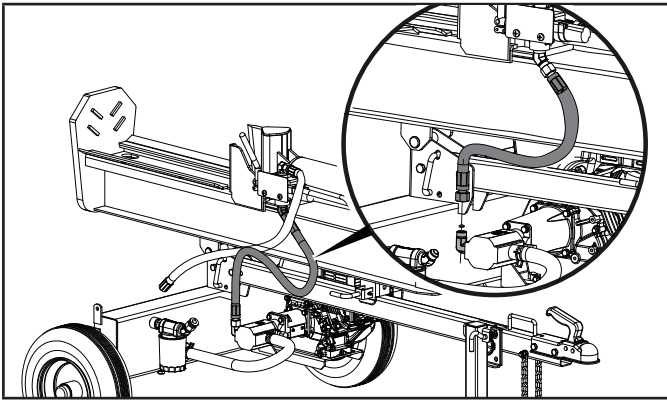

Oil Return (Low Pressure) Hose

5. Thread the loose end of the low pressure hydraulic hose onto the tapered hydraulic fitting on the hydraulic fluid tank. This hose fitting will only fit on this fitting to ensure correct connection.
6. Securely tighten the fitting with a 27mm wrench. Tighten to 52 lbf-ft - 66 lbf-ft (70.5-89.5 Nm). Make sure the fitting, when fully tightened is angled upward as shown.

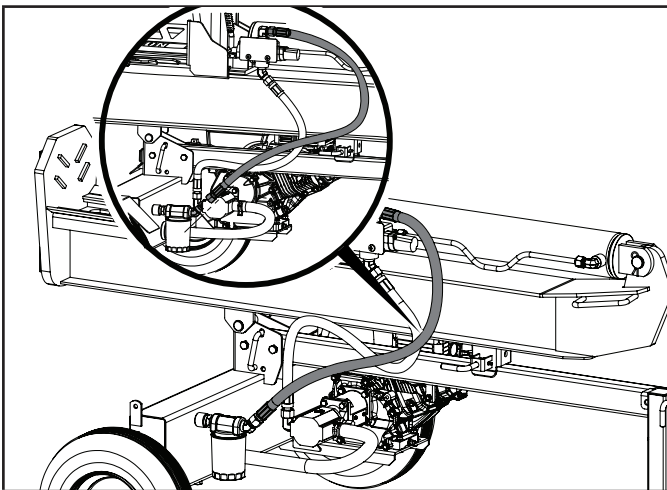

6) Install the Log Catchers

Large Log Catcher (Engine Side)

1. With the log catcher angled upward, align the four holes on the log catcher with the 4 threaded holes on the splitter beam.
2. Place a $\varnothing 10$ flat washers and $\varnothing 10$ lock washers onto the four M10 \times 20 bolts and thread them through the holes on the log catcher and into the holes on the splitter beam and tighten securely.

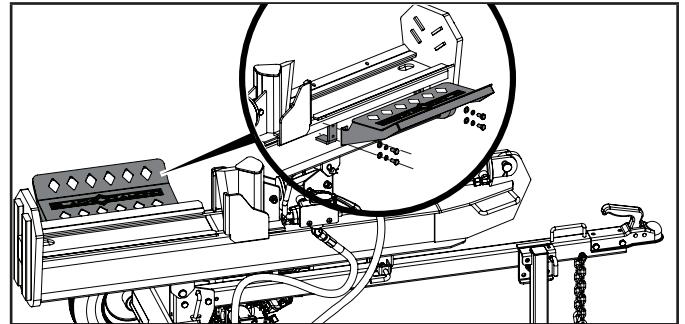

Small Log Catcher (Hydraulic Hose Side)

3. With the log catcher angled downward and under the lip of the splitter beam, align the two holes on the log catcher with the two holes on the beam lip.
4. Place the two M10 \times 30 bolts through the holes on the beam and through the holes on the log catcher. Place a $\varnothing 10$ flat washer and a $\varnothing 10$ lock washer onto the bolt from the bottom side and thread the M10 nuts onto the bolts and tighten securely.

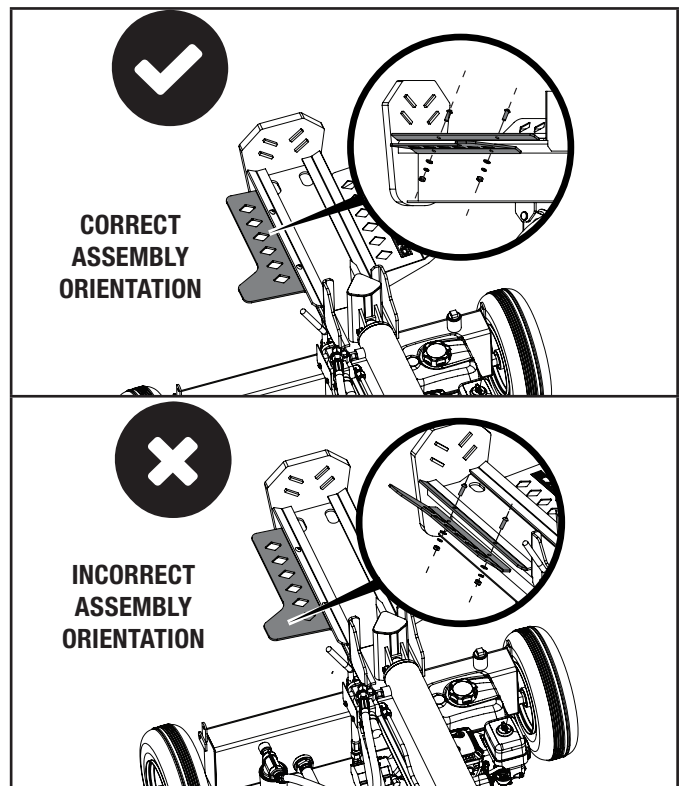

Add Engine Oil

Refer to Honda's engine owner/operator manual.

Add Fuel

Refer to Honda's engine owner/operator manual.

Add Hydraulic Oil

If your log splitter was delivered pre-assembled, follow these instructions:

1. Position the log splitter on a flat, level surface.
2. Remove the plastic shipping plug from the oil tank on the top of the tank (A) and discard. Replace with the steel oil plug (with breather hole) shipped with your log splitter (A).

CAUTION

Do not run the log splitter with the temporary oil tank shipping plug.

Pressure will build up inside the tank and potential damage could occur.

3. After running and cycling the unit several minutes (purging air from the system), turn off the engine and check the hydraulic oil level using the oil sight glass. Oil level should visibly fill the glass sight.

If your log splitter was delivered unassembled, follow these instructions:

1. Make sure the log splitter is on a flat, level surface.
2. Remove the oil plug from the oil tank (A).
3. Add 5 gal (18.9 L) of hydraulic oil - see specification section for types of acceptable oil.
4. Check the hydraulic oil level using the oil sight glass. Oil level should visibly fill the sight glass.

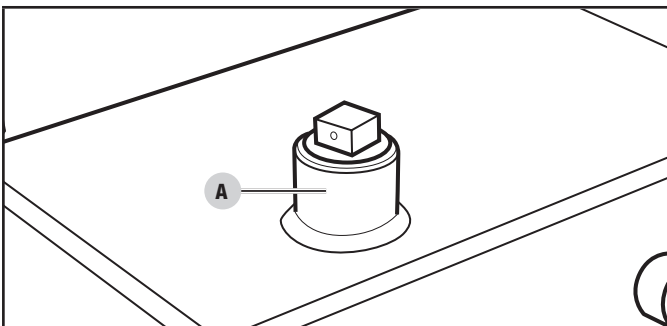

WARNING

DO NOT remove the hydraulic oil fill cap when the engine is running or hot. Hot oil can escape causing severe burns. Always allow the log splitter to cool completely before removing the hydraulic oil cap.

High fluid pressure and temperatures are created in the hydraulic log splitters. Hydraulic fluid will escape through a pin-size hole opening and can puncture skin and cause severe blood poisoning.

Inspect hydraulic system regularly for possible leaks. Never check for leaks with your hand while the system is pressurized. Seek medical attention immediately if injured by escaping fluid.

5. Replace and tighten the oil plug and orient the vent hole away from the operator zone.
6. Start Engine. (See starting the engine section)
7. Extend and retract the wedge to purge air from the hydraulic system. When the wedge motion is smooth, the system is properly purged.
8. Check the hydraulic oil tank sight glass. Add approximately 1 gal. (3.8 L) of hydraulic oil to bring the level back up to the sight glass. Do NOT overfill.
9. Check oil level daily and add as needed.

NOTICE

When the outdoor temperature is below 32°F (0°C), Dexron III transmission fluid can be used. Do not mix hydraulic oil and transmission fluid. Drain all oil or fluid before adding the other one.

See hydraulic oil system specifications section for more details.

NOTICE

To check oil level, place on level surface and use the oil sight glass on the tank. The oil sight glass has a marker for the acceptable level of oil. If oil is below the marker, add oil as needed. DO NOT OVERFILL.

OPERATION

Before Each Use Inspect the Log Splitter

1. Check the hydraulic oil level and visually inspect all hoses, attachments and cylinder for loose fittings, leaks, cracks, fraying or other damage.
2. DO NOT operate the log splitter if there is any indication of damage.
3. Inspect the engine and make sure the oil level is correct before operating. If the engine is equipped with a spark arrestor, clean and inspect it regularly (follow spark arrestor maintenance schedule).
4. The tires need to be fully inflated and in good repair. Reference the tire sidewall for recommended tire pressure.

⚠ WARNING

DO NOT over inflate tires. Serious injury can result if tires explode.

DO NOT tow the log splitter if the tires are worn or will not hold air.

DO NOT exceed the maximum 45 MPH (72 KM/H) towing speed.

Changing Beam from Horizontal to Vertical Orientation

When logs are too heavy to lift, log splitter beam can be moved from horizontal to vertical orientation.

To change from horizontal to vertical orientation:

1. Block the wheels to prevent the unit from rolling.
2. Pull the spring loaded pin out on the horizontal beam lock attached to the tow bar to release the beam. Standing alongside the hydraulic ram, (opposite side from the engine) firmly grasp the handle on the beam and lift upward while pushing the beam back until upright. (Caution, beam is heavy.)

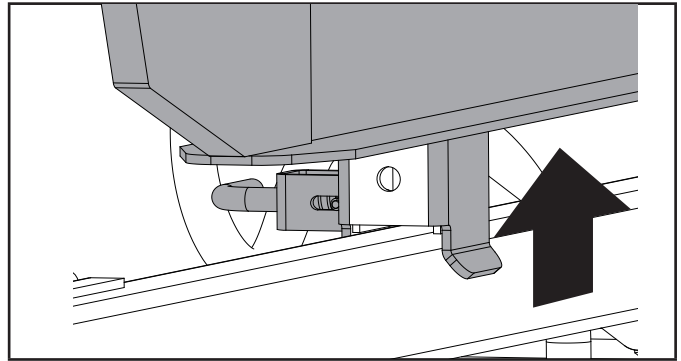
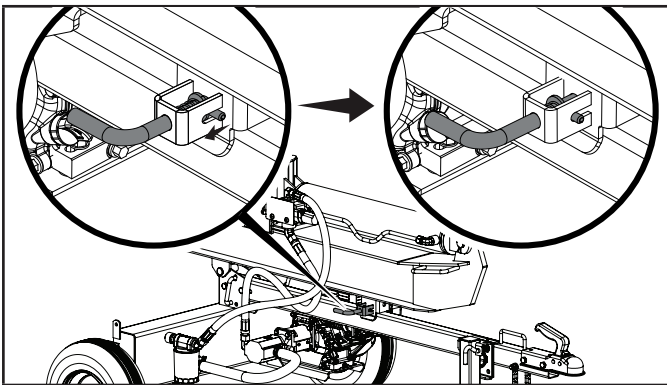

3. Pull out the spring loaded quick-lock pin and rotate it around to the 9 o'clock position around the lip on the beam to secure it in the vertical position.

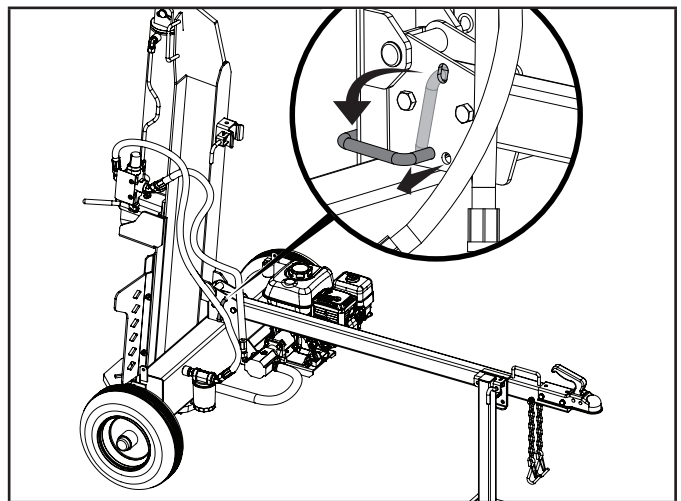

4. To change from vertical to horizontal orientation, reverse the steps. The beam will automatically lock into the auto-lock on the tow bar when lowered into position.

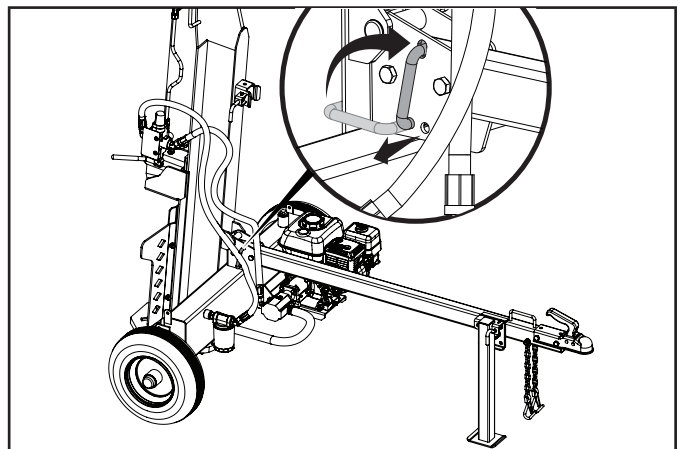

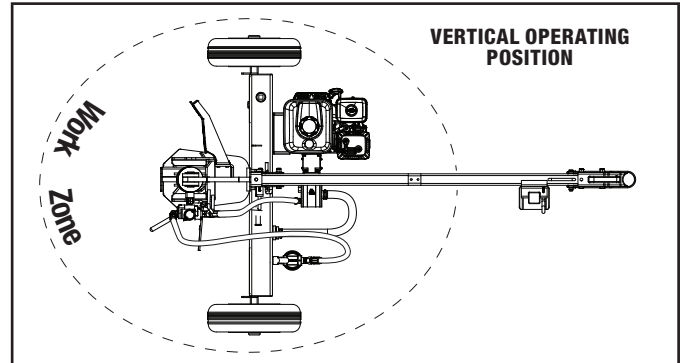
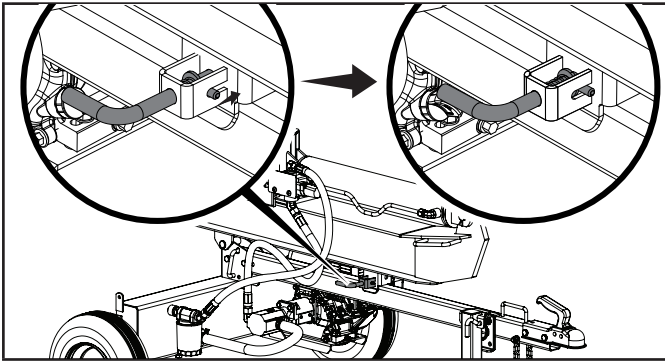

Towing Log Splitter Safety

1. Always check local, state or provincial regulations regarding towing, licensing and lights before towing your log splitter. Review towing safety warnings in your towing vehicle manual.
2. Before towing make sure the log splitter is correctly and securely attached to the vehicle and the safety chains attached with enough slack to allow for turning.
3. Support leg must be pinned in the "UP" position for towing.
4. Never exceed the max. travel speed of 45 mph (72 km/h). Towing the log splitter at speeds greater than 45 mph (72 km/h) could result in serious injury or death. Always adjust your towing speed according to the terrain and conditions.
5. Always disconnect the log splitter from the towing vehicle before operating.

Log Splitter Location

This log splitter must have at least seven feet of clearance from combustible material. Leave at least three feet of clearance on all sides of the log splitter to allow for adequate cooling, maintenance and servicing. **DO NOT** place the log splitter near vents or intakes where engine exhaust fumes could be drawn into occupied or confined spaces. **ONLY operate the log splitter outdoors.**

The log splitter needs to be on a dry level surface with good footing. **DO NOT** work on mud, ice, tall grass, brush or snow.

Only operate log splitter from work zone shown below.

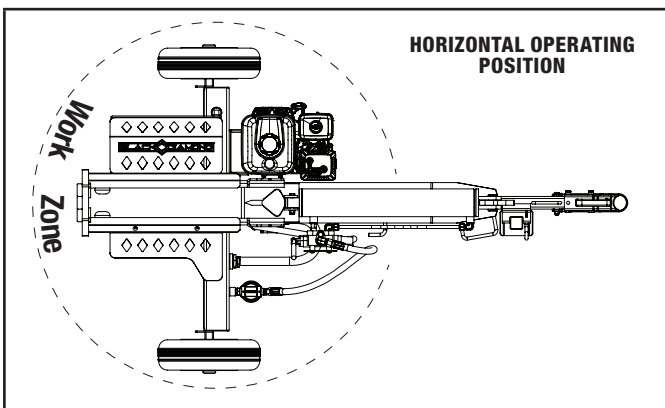

NOTICE

For Vertical Operation:

- Remove the beam lock-pin from the beam bracket
- Use handle on cylinder to rotate beam to vertical position.
- Insert beam lock-pin in the pivot bracket.

WARNING

ALWAYS use the log splitter for its intended use. The log splitter should only be used to split wood logs, length wise with the grain.

NEVER modify, alter or change the log splitter in anyway. Modifications will void the warranty.

NEVER attach a rope, cable or other device to the control lever on the log splitter.

DO NOT modify or change the engine and operating speeds or pressure settings. These changes can cause safety issues.

ONLY operate the log splitter in daylight.

NEVER operate, or let anyone else operate the log splitter while under the influence of alcohol, drugs, or medication.

NEVER leave the log splitter unattended while the engine is running.

DO NOT change the splitting position with the engine running. Contact with the muffler can cause serious burns.

ALWAYS make sure the beam is in the locked position.

DO NOT let the beam drop as it could crush fingers or cause damage to the log splitter.

Starting the Engine

Refer to Honda's engine owner/operator manual.

DANGER

Always operate log splitter outdoors and far away from building, windows, doors and intake ventilation covers.

OPERATION

Stopping the Engine

Refer to Honda's engine owner/operator manual.

Log Splitter Operation

1. ALWAYS wear ear and eye protection, protective clothing and safety gear.

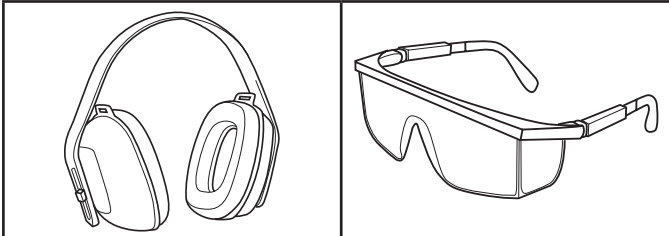

2. Block tires and ensure support leg is secure to prevent unintended movement of the log splitter during operation.
3. Set log splitter in either the horizontal or vertical position.

NOTICE

HORIZONTAL position is used for lighter logs that can easily be loaded onto the beam.

VERTICAL position is used for light logs as well as heavy logs that are difficult to load onto the beam.

Back injury can result from lifting logs onto the log splitter if proper lifting techniques are not used.

4. Load a log onto the beam against the end plate (MAX LOG LENGTH – 24 in. [61 cm]).
5. To stabilize the log, place your left hand on the side of the log.

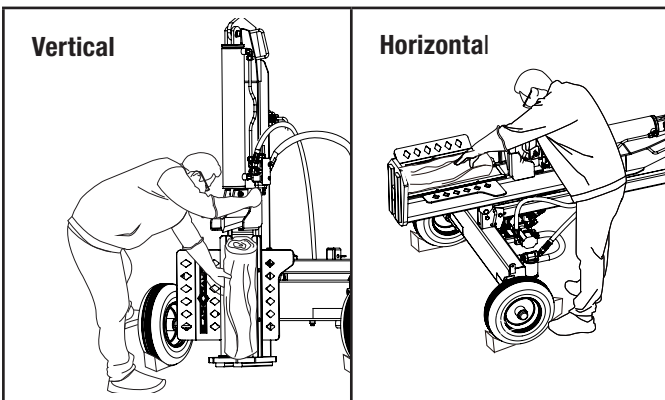

WARNING

Never place your hand on the ends of the log, between the log and end plate or the log and the splitting wedge.

WARNING

Only one operator permitted. The adult who loads and stabilizes the log, must be the person who operates the control handle.

6. Make sure all limbs are clear of crush zones.
7. Use your right hand to push the control valve handle forward (towards the end plate) to split the log.
8. Remove left hand from the log once the wedge begins to contact with the log. Continue holding the control handle in the forward position until the log splits.
9. Push the auto control valve handle backward to return the wedge to its original position.
10. Clear the split wood from the work zone.

NOTICE

It is normal for the hydraulic fluid to appear foamy/frothy during operation. This can be caused by agitated oil in the tank collecting air.

NOTICE

If a log gets stuck, embedded or will not split completely, push the control handle in the reverse direction and allow the splitter to strip the log from the wedge.

ALWAYS keep hands clear of the log and wedge while it is retracting.

NOTICE

The cylinder stroke is designed so the wedge stops approximately 1.5 in. (3.8 cm) from the end plate.

Operation at High Altitude

Refer to Honda's engine owner/operator manual.

MAINTENANCE

Make certain that the log splitter is kept clean and stored properly. Only operate the unit on a flat, level surface in a clean, dry operating environment. DO NOT expose the unit to extreme conditions, excessive dust, dirt, moisture or corrosive vapors. Inspect all air vents and cooling slots to ensure that they are clean and unobstructed.

Clean spark arrester every 100 hours.

Check and tighten all bolts and nuts before operating the log splitter.

⚠ WARNING

Never operate a damaged or defective log splitter.

⚠ WARNING

Improper maintenance will void your warranty.

🗨 NOTICE

For Emission control devices and systems, read and understand your responsibilities for service as stated in the Emission Control Warranty Statement of the Honda engine's operator manual.

The owner/operator is responsible for all periodic maintenance.

Complete all scheduled maintenance in a timely manner.

Correct any issue before operating the log splitter.

For service or parts assistance, contact our Technical Support Team at 1-888-376-7375.

Cleaning the Log splitter

⚠ CAUTION

DO NOT spray engine with water.

Water can contaminate the fuel system and can enter the engine through the cooling slots and damage the engine.

Clear the debris from the beam, wedge and endplate.

Use a damp cloth to clean exterior surfaces of the engine and log splitter.

Use a soft bristle brush to remove excess dirt and oil. Use an air compressor (25 PSI) to clear dirt and small debris.

Wipe all metal parts with an oily rag to help prevent rust and corrosion.

Changing the Engine Oil

Refer to Honda's engine owner/operator manual.

Cleaning and Adjusting the Spark Plug(s)

Refer to Honda's engine owner/operator manual.

Cleaning the Air Filter

Refer to Honda's engine owner/operator manual.

Changing the Hydraulic Oil

Always shut off the engine, disconnect the spark plug.

Change the hydraulic oil filter after the first 50 hours of use, then every 100 hours or seasonally.

🗨 NOTICE

When log splitters are not used for extended periods of time and they are exposed to changing temperature conditions, moisture through condensation can build up inside the tank.

1. Begin with the cylinder retracted and the engine fuel valve in the "OFF" position.
2. Release any stored pressure by moving the valve lever forward and backward several times.
3. Place a container under the hydraulic tank. Make sure it is large enough to hold the contents of the tank. See model specification section of this manual for hydraulic oil capacities.

🗨 NOTICE

The drain plug is sealed with Teflon® tape. Add 2-3 wraps of new Teflon® tape as needed when replacing the drain plug to prevent oil leak.

4. To drain the oil,
 - Place an oil drain container under the drain plug. Unscrew (counter-clockwise) and remove the tank drain plug on the bottom of the hydraulic tank. Allow oil to completely drain from the tank into the container. Re-apply Teflon® sealing tape to the drain plug threads, then reinsert and turn (clockwise) in the tank drain plug. Tighten, but do not over tighten.
 - Place an oil drain container under the external oil filter. Unscrew (counter-clockwise) and remove the external hydraulic oil filter and drain any oil in the filter into the container. A strap or oil filter wrench may be needed.

🗨 NOTICE

Oil will drain from the filter and filter housing.

MAINTENANCE

- Locate an approved replacement filter.
- Lubricate the gasket of the new filter with a thin film of clean oil.
- Install a new hydraulic oil filter (A). Screw the new filter on clockwise. Tighten 3/4 - 1 turn after the gasket makes contact.

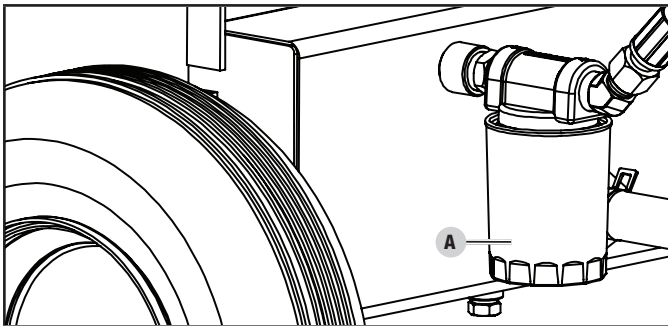

NOTICE

Install a new hydraulic oil filter each time the hydraulic oil is changed (if your log splitter includes this feature).

- Place an oil drain container under the large clear hose that runs from the tank to the pump.
- Loosen the hose clamp attached to the fitting on the tank.
- Disconnect hose from fitting and drain oil into the container.
- Using a large wrench, unscrew the fitting from the tank to expose the internal tank filter.
- Check for any debris on the screen. Using a clean towel or air gun, carefully remove any debris.

NOTICE

Be careful when handling the screen as it can be easily damaged.

- Apply new Teflon® sealing tape to threads, reinsert into tank and tighten. Be careful to tighten, but do not over tighten.
5. Unscrew and remove the tank fill plug on top of the tank (B). Using a funnel, add approximately 5 gal (18.9 L) of hydraulic oil to the tank. Wipe up any spilled oil.
 6. Turn the fuel valve to the “ON” position, and start the engine. Purge the air from the system by extending and retracting the wedge several times until the motion is smooth.

7. Check the hydraulic oil level using the sight glass. Add 1 gal (3.8 L) of hydraulic oil, so the oil level is visible in the sight glass (C).

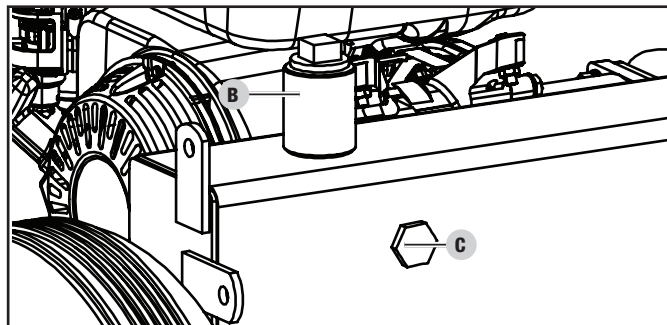

8. Dispose of used oil at approved recycling locations in accordance with Federal, State, Local or Provincial regulations.

WARNING

Always shut off the engine, disconnect the spark plug, and relieve system pressure before cleaning, adjusting, or repairing the splitter. Relieve system pressure by moving split control lever back and forth several times

NOTICE

Refer to *Specifications* for a list of compatible replacement filters or call Black Diamond at 1-888-376-7375 to order a replacement OEM filter.

Maintenance Schedule

Follow the service intervals indicated in the following maintenance schedule.

Service your log splitter more frequently when operating in adverse conditions.

Contact our Technical Support Team at 1-888-376-7375 to locate the nearest Black Diamond certified service dealer for your log splitter or engine maintenance needs.

For engine maintenance schedule, refer to Honda's engine owner/operator manual.

EVERY 8 HOURS OR DAILY

- Check hydraulic oil levels
- Clean around air intake and muffler

EVERY 100 HOURS OR EVERY SEASON

- Change hydraulic oil
- Change hydraulic oil filter

MAINTENANCE

EVERY YEAR

- Inspect wheel bearings and repack bearing grease as needed.

**To be performed by knowledgeable, experienced owners or Black Diamond certified service centers.*

Refer to the *Maintenance* section for proper cleaning instructions.

Log Splitter Storage

1. The log splitter needs to be cool for at least 5 minutes before storing.
2. Clean the log splitter before storage according to the *Maintenance* section.
3. Retract the wedge to protect the rod from corrosion.
4. Wipe the beam and wedge with an oily rag to prevent rust and corrosion.

⚠ WARNING

Never store the log splitter indoors next to appliances where there is a source of heat or open flame, spark or pilot light because they can ignite gasoline vapors.

DO NOT store a log splitter near fertilizer or any corrosive material. Even with an empty gas tank, gasoline vapors could ignite.

Engine Storage

Refer to Honda's engine owner/operator manual.

SPECIFICATIONS

Log Splitter Specifications

Ram Force	38 Ton
Cycle Time	17 seconds
Hydraulic Tank Capacity	5 gal (18.9 L)
Max Log Length	24 in. (61 cm)
Max Log Weight	100 lb. (45 kg)
Coupler Ball Size	2 in. (5.1 cm)
Tire Size	16 in. (40.6 cm)
Max towing speed	45 MPH (72 KM/H)
Cylinder size	5 in. × 23 in. (12.7 cm × 58.4 cm)
Cylinder rod size	1.8 in. (4.5 cm)
Gear Pump	2-stage
Max pressure	3900 psi
Max flow capacity	14 GPM (53 LPM)
Control Valve	Detent (auto-return)
Net Weight	542 lb. (246 kg)
Length	86.3 in. (219.2 cm)
Width	51.3 in. (130.2 cm)
Height	41.7 in. (105.8 cm)

Hydraulic Oil System

Capacity

Capacity	6 gal. (22.7 L)
----------------	-----------------

For year round use in warmer climates (always ABOVE 32°F/ 0°C):

- ISO 32/SAE10W
- Universal Hydraulic Oil
- Recommend: Harvest King HK011 and HK012

For year round use in colder climates (BELOW 32°F/ 0°C):

- Automatic Transmission Fluid
- Recommend: Harvest King HK080, HK081, and HK082

Replacement filters:

- Fram PH9342
- K&N HP-2008
- Wix 51361

Engine Specifications

Refer to Honda's engine owner/operator manual.

Spark Plug Specifications

Refer to Honda's engine owner/operator manual.

Valve Specifications

Refer to Honda's engine owner/operator manual.

Oil Specifications

Refer to Honda's engine owner/operator manual.

Fuel Specifications

Refer to Honda's engine owner/operator manual.

Important Message About Temperature

Refer to Honda's engine owner/operator manual.

TROUBLESHOOTING

Problem	Cause	Solution
Engine will not start.	No fuel.	Add fuel.
	Faulty spark plug.	Replace spark plug.
	Unit loaded during start up.	Remove load from unit.
Engine will not start; Engine starts but runs roughly.	Low oil level.	Fill crankcase to the proper level. Place log splitter on a flat, level surface.
	Choke in the wrong position.	Adjust choke.
	Spark plug wire loose.	Attach wire to spark plug.
Engine shuts down during operation.	Out of fuel.	Fill fuel tank.
	Low oil level.	Fill crankcase to the proper level. Place log splitter on a flat, level surface.
Engine cannot supply enough power or overheating.	Insufficient ventilation.	Check for air restriction. Move to a well ventilated area.
Wedge movement is slow or erratic.	Air in the hydraulic oil system.	Purge air by extending and retracting the wedge several times until motion is smooth.
	Debris lodged in beam guides.	Clear debris from beam.
	Low hydraulic oil.	Check oil level and add as needed.
Oil leak from cylinder.	Faulty cylinder rod seal.	Contact Customer Service.
	Scored or bent cylinder rod.	Contact Customer Service.
	Loose hydraulic fitting.	Tighten hydraulic fitting.
	Faulty combination washer seal on cylinder hydraulic fitting.	Contact Customer Service.
Wedge will not extend or retract.	Faulty control valve.	Contact Customer Service.
	Faulty hydraulic pump.	Contact Customer Service.
	Low hydraulic oil.	Check oil level and add as needed.
Excessive bouncing while towing.	Under-inflated tires.	Inflate tires to proper pressure. Refer to tire sidewall.

For further technical support:

Technical Support Team
Toll Free 1-888-376-7375

WARRANTY

CHAMPION POWER EQUIPMENT
2 YEAR LIMITED WARRANTY

Warranty Qualifications

To register your product for warranty and FREE lifetime call center technical support please visit:

<https://www.championpowerequipment.com/register>

To complete registration you will need to include a copy of the purchase receipt as proof of original purchase. Proof of purchase is required for warranty service. Please register within ten (10) days from date of purchase.

Repair/Replacement Warranty

CPE warrants to the original purchaser that the mechanical and electrical components will be free of defects in material and workmanship for a period of two years (parts and labor) from the original date of purchase and 180 days (parts and labor) for commercial and industrial use. Transportation charges on product submitted for repair or replacement under this warranty are the sole responsibility of the purchaser. This warranty only applies to the original purchaser and is not transferable.

Do Not Return The Unit To The Place Of Purchase

Contact CPE's Technical Service and CPE will troubleshoot any issue via phone or e-mail. If the problem is not corrected by this method, CPE will, at its option, authorize evaluation, repair or replacement of the defective part or component at a CPE Service Center. CPE will provide you with a case number for warranty service. Please keep it for future reference. Repairs or replacements without prior authorization, or at an unauthorized repair facility, will not be covered by this warranty.

Warranty Exclusions

This warranty does not cover the following repairs and equipment:

Normal Wear

Products with mechanical and electrical components need periodic parts and service to perform well. This warranty does not cover repair when normal use has exhausted the life of a part or the equipment.

Installation, Use and Maintenance

This warranty will not apply to parts and/or labor if the product is deemed to have been misused, neglected, involved in an accident, abused, loaded beyond the product's limits, modified, installed improperly or connected incorrectly to any electrical component. Normal maintenance is not covered by this warranty and is not required to be performed at a facility or by a person authorized by CPE.

Other Exclusions

This warranty excludes:

- Cosmetic defects such as paint, decals, etc.
- Wear items such as filter elements, o-rings, etc.
- Accessory parts such as hoses, storage covers, etc.
- Failures due to acts of God and other force majeure events beyond the manufacturer's control.
- Problems caused by parts that are not original Champion Power Equipment parts.

Limits of Implied Warranty and Consequential Damage

Champion Power Equipment disclaims any obligation to cover any loss of time, use of this product, freight, or any incidental or consequential claim by anyone from using this product. THIS WARRANTY AND THE ATTACHED U.S. EPA and/or CARB EMISSION CONTROL SYSTEM WARRANTIES (WHEN APPLICABLE) ARE IN LIEU OF ALL OTHER WARRANTIES, EXPRESS OR IMPLIED, INCLUDING WARRANTIES OF MERCHANTABILITY OR FITNESS FOR A PARTICULAR PURPOSE.

This warranty gives you certain legal rights which may change from state to state or province to province. Your state or province may also have other rights you may be entitled to that are not listed within this warranty.

Contact Information

Address

Mid-States Distributing, LLC.
2800 Meacham Blvd.
Fort Worth, TX 76137 USA
www.black-diamond.com

Customer Service

Toll Free: 1-888-376-7375
info@black-diamond.com

*Except as otherwise stipulated in any of the following enclosed Emission Control System Warranties (when applicable) for the Emission Control System: U.S. Environment Protection Agency (EPA) and/or California Air Resources Board (CARB).